



**ANATOLIAN
ROVER CHALLENGE**

— 2023 —

Design Report

TEAM INFO



Team Name:

Adastra Rover

Contact:

<https://www.instagram.com/adastraroverteam/>

adastra

TEAM INFO

**Academic
Institution:**

Bahcesehir University

**Academic
Consultant:**

Mahmut AĞAN

TEAM INFO



History of the Team:

The AdAstra Rover Team was established by five first-year students at Bahçeşehir University in March 2022. Today, the AdAstra robotics team includes 12 students from four different fields: Mechatronics Engineering, Electrical and Electronics Engineering, Computer Engineering, and Software Engineering. The team is developing projects for three different competitions.

adastra

TEAM INFO

Active Members List:

Names	Role	Grade	Major
OrkunKoray Taner	Team Leader	2nd	CmpE
Polat Öztürk	Software Leader	2nd	EEE&CmpE
Elçin Can	Software Member	3rd	CmpE
Semican Eroğlu	Mechanic Member	4th	ME
Salim Kaya	Mechanic Leader	2nd	ME
AbubakrSuliman	Mechanic Member	2nd	ME
Ceyda Yılmaz	Organization Leader	2nd	ME
Ece Kadioğlu	Organization Member	2nd	ME
Muazzez Çizen	Organization Member	2nd	EEE
Çağla Taşkın	Science Leader	2nd	MBG

TEAM INFO

Team Photo



adastra

MANAGEMENT

Work Calendar:

◆ Explain the work on the project by a Gantt chart. Include 10-15 items in the Gantt chart.

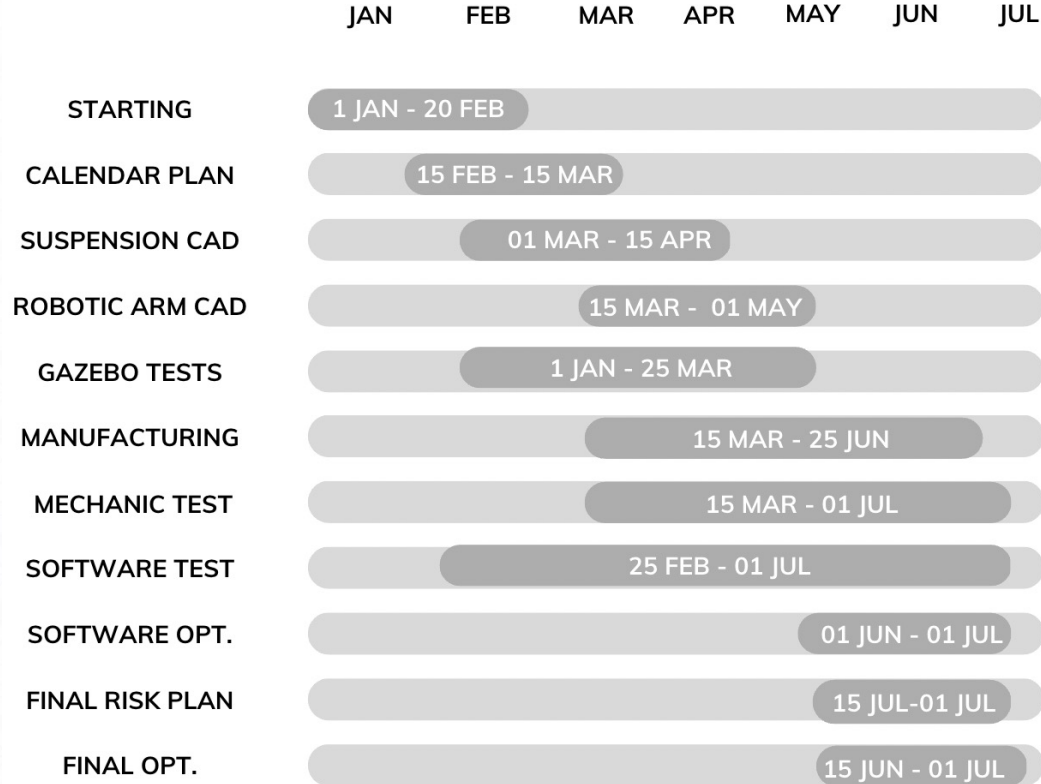

MANAGEMENT

Team Formation:

Our team consists of 12 students, all of whom study engineering at Bahcesehir University. We have one team leader and three subteam leaders. Subteam leaders are mainly responsible for the workload in their respective areas and for managing their team members. For example, when a subteam starts a new job, the subteam leader must organize their subteam and its members. If a problem occurs in a specific area, we hold the subteam leaders accountable

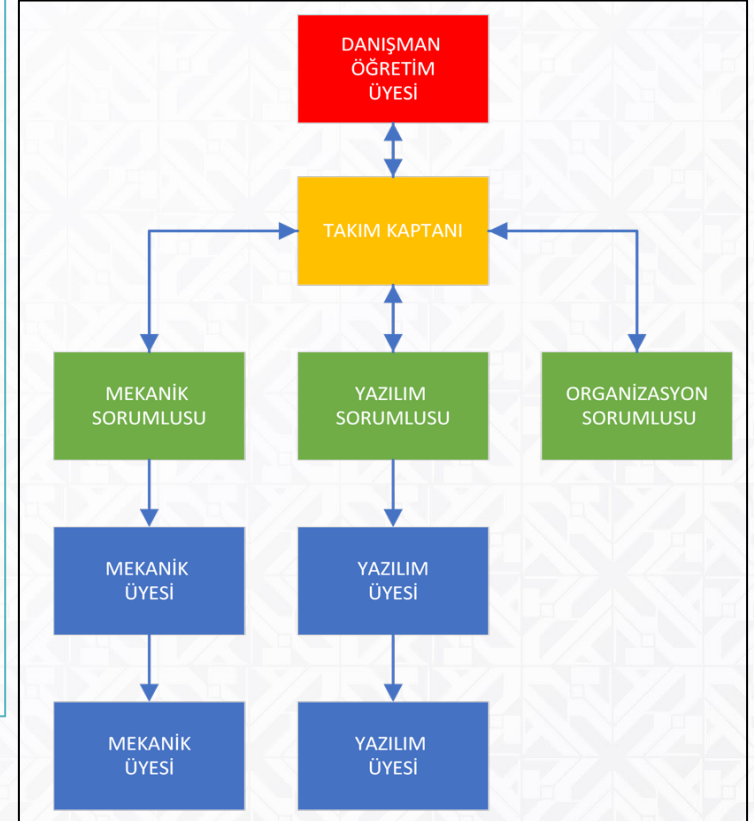

MANAGEMENT

Workplace:

We are using our electric and mechanic lab for our Rover design. In this lab



adastra

MANAGEMENT

Funding :

- ◆ We have three different budget for our competition:
 1. Bahcesehir University LOAP (for ARC): 925\$
 2. Bahcesehir Univeristy LOAP (for Teknofest):925\$ (already used)
 3. Teknofest Finalist Budget:770\$ (already used)

- ◆ For the development and manufacture of the manipulator of rover we are expecting to spend at least \$500 and for the other parts of the rover that is going to be upgraded such as wheels and motor we are expecting to spend \$200.

- ◆ Team's plan in an insufficient funding situation is to provide the funding from the sponsors.

MANAGEMENT

Logistics:

All team members live in Istanbul, Turkey. We are planning to use our university's transfer system for transportation between Ankara and Istanbul. For ground transportation, we are using a handcart for the Rover. That's all we have planned for transportation

ROVER DESIGN

Mobility System:

Our rover consists of 4 wheels. We used store bought wheels in our system. Each wheel is actuated with DC motors. To increase the torque in the wheels we used 1:188 gearboxes. We used sigma profiles for the legs of the rover.

The main reason why we chose this system is that it was the most affordable one we could build. Although it is cheap our rover is quite robust. Because of the limited budget we could not apply any suspension system in our rover.

adastra

ROVER DESIGN

Mobility System:

The most unique feature in our rover is that it is fully made from sigma profiles. Because of this feature, even though the vehicle is lightweight, it is quite robust. Another reason why we used sigma profiles is that they are cheaper to buy compared to the parts manufactured by CNC machines. Also, our rover is designed to deal with rough terrains even without a suspension system.

ROVER DESIGN

Mobility
System:

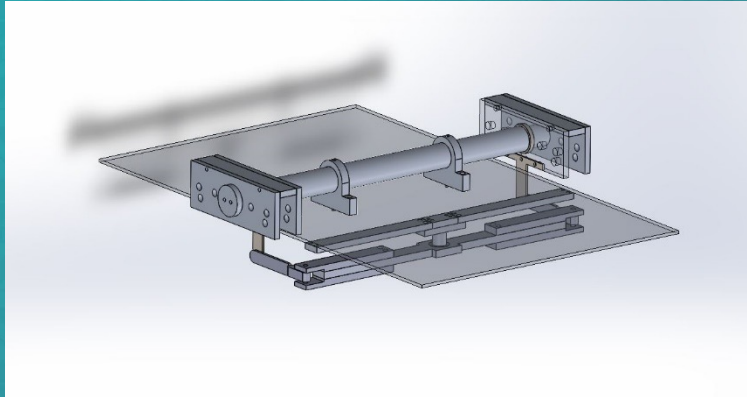

Isolated Rocker Suspension System



Rover's Left View

adastra

ROVER DESIGN

Mobility System:

Our rover has the dimensions of 700x900x550 mm and weights around 40kg without the manipulator. Each wheel weights around 5kg with electronics inside them. Because the sigma profiles have empty channels going through inside, we can make quick adjustments, add new parts on rover's frame or simply take advantage from its lightweight.

Even though our current design lacks a suspension system, our rover proved to overcome rough terrains in our latest competition. Still, by the time of competition we are planning to use our new budget for a newly designed suspension system. Additionally, we will be using TPU printed tires in our wheels.

ROVER DESIGN

Electronics and power system:

Our battery is 4.2 kg, 22.2V 32Ah. We calculated that on full power our robot absorb approximately 500 watt so rover can run 1 hour. We use power distribution board for the supply 5,12 and 54 volt for the logic and network systems.

One of our strenght is our batterys capacity it is 32Ah so our rover can run 1 hour in full power. And our other strenght is our network system it can communicate very long distances. And our other strenght is we use IP camera on our base computer and web camera on our main computer so we divide our algorithms thus our processing capacity doubled.

ROVER DESIGN

Electronics and power system:

We drew inspiration from Tesla Inc. and decided to use only normal cameras for our rover, instead of lidar or stereo cameras. We process the images from our cameras, and all algorithms that rely on this data perform depth estimation and object detection from the normal camera feed. We use very high Ah battery so our rover can handle a lot of process that require high energy.

adastra

ROVER DESIGN

Electronics
and power
system:

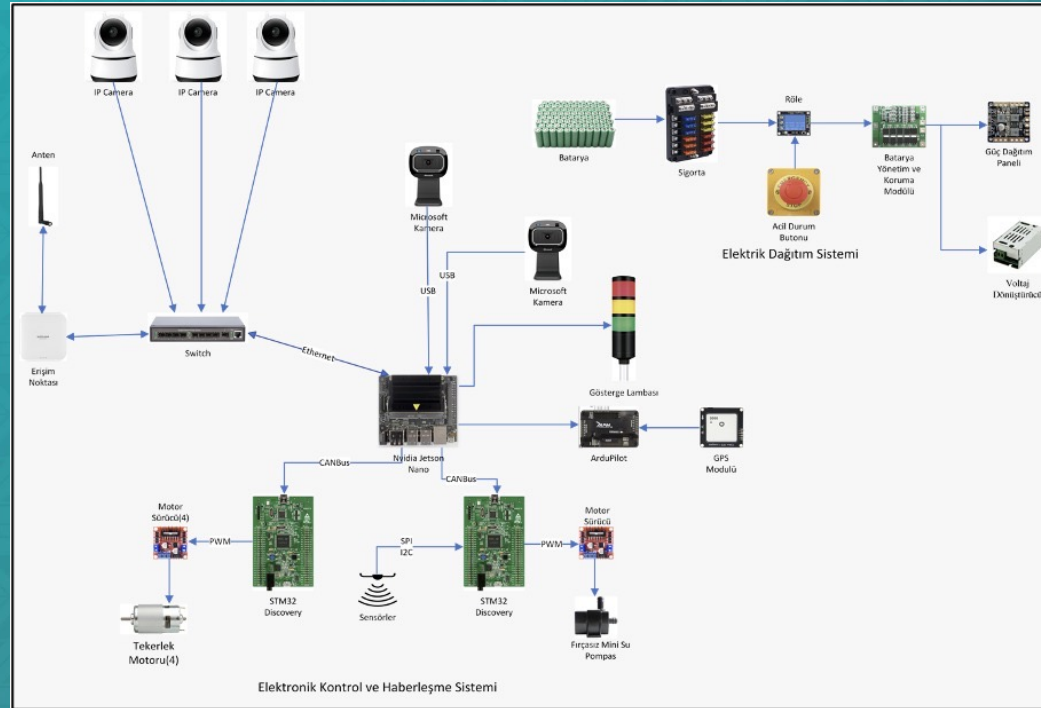

adastra

ROVER DESIGN

Electronics and power system:

Our battery is 4.2 kg, 22.2V 32Ah we calculated that on full power our robot absorb approximately 500 watt so rover can run 1 hour.

According to the manual, the landing and field excursion phases will take a maximum of 30 minutes, so the battery of our rover is sufficient for this mission. Our motor controllers can withstand up to 40 amperes, making them safe for any scenario during the mission. We use temperature sensors on any device that could overheat, allowing us to monitor their status from the base station.

ROVER DESIGN



Manipulation system:

Our rover currently lack a manipulator system. However, our mechanics sub-team is on the process of design. We our planning to design a manipulator with 5 degrees of freedom and each joint actuated by a stepper motor. For manipulators skeleton we will be using 20x20 mm sigma profiles and 3D printed parts with ABS filament for the joint pieces. For our gripper parts we will be using 3D printed and laser cut acrylic plates.

We have chosen to go with designs because we believe them to be the best approach for our team's current goals and situations. Sigma profiles are cheap, lightweight and very easy to use. Because they are light weight stepper motors won't be having problem while rotating the joints. Additionally, we can use pneumatic linear actuators to apply supporting torque for the motors.

adastra

ROVER DESIGN

Manipulation system:

Just like in the mobility system, one of our most unique point is to use sigma profiles. Also, instead of using DC motors with gearboxes, we plan to use stepper motors. While designing the manipulator we take inspirations from Fanuc's LR-Mate model robots. Although we are not using their all features, we are designing joint lengths and their placements accordingly.

adastra

ROVER DESIGN

Manipulation
system:

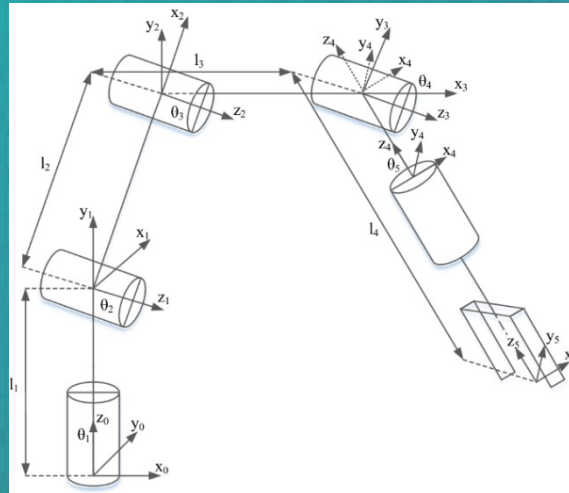

Joint Layout of Manipulator

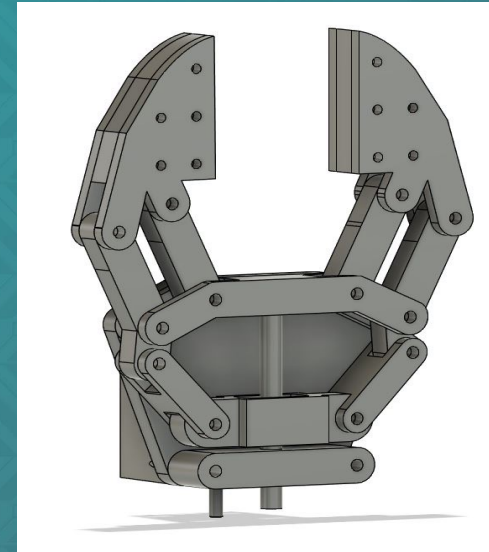

Our Current Gripper Design

adastra

ROVER DESIGN

Manipulation system:

Since we are still in the design process for the manipulator, we can only estimate its physical specifications. We are planning to make the manipulator weight around 10-15 kg and have around 1 m reaching capacity. Our manipulator should be able to handle around 3kg payload, but if we use pneumatic linear actuators to support, payload could go up to 5 kg.

If we use our time efficiently and get more budget, we can build the system described above until July. We believe with these features our manipulator should overcome any challenge and missions given to itself.

adastra

ROVER DESIGN

Science Payload:

During the preparation of the powder samples, all electrically mortar grinders (mullite mortars) will be used. While hydroxylamine hydrochloride solution, rtophenanthroline solution, sodium citrate and the solution prepared to assist the calculation are used in the calculation of the total iron content, acid blank solution, polyvinyl alcohol mixture solution, water, complex solution, thiazole yellow reagent solution, and NaOH solution are used when calculating the magnesium amount.

The experiments to be carried out are based on the rapid analysis of the collected rocks. The applicability of the method to investigate the presence of magnesium on silica rocks may create a problem if there is no silicate in the samples collected as stated in the hypothesis. However, it is important to test the hypothesis that the method by which the iron will be searched is applicable on phosphate, carbonate, and silicate rocks, because the collected rocks may contain carbonate or phosphate even if they do not contain silicates. As a result, if we find the iron content, we can conclude that there was water on Mars in the past and therefore there was life on Mars in the past.

adastra

ROVER DESIGN

Science Payload:

The hypothesis in the science report is that Oxia Planum contains iron, magnesium and hydrated silica. The experimental phase was inspired by the mineral analysis experiments performed by Leonard Shapiro and W.W. Brannock on silica, carbonate and phosphate rocks. It is especially important to detect iron because it requires water to form and knowing that there was water in the past is associated with life.

adastra

ROVER DESIGN

Science
Payload:

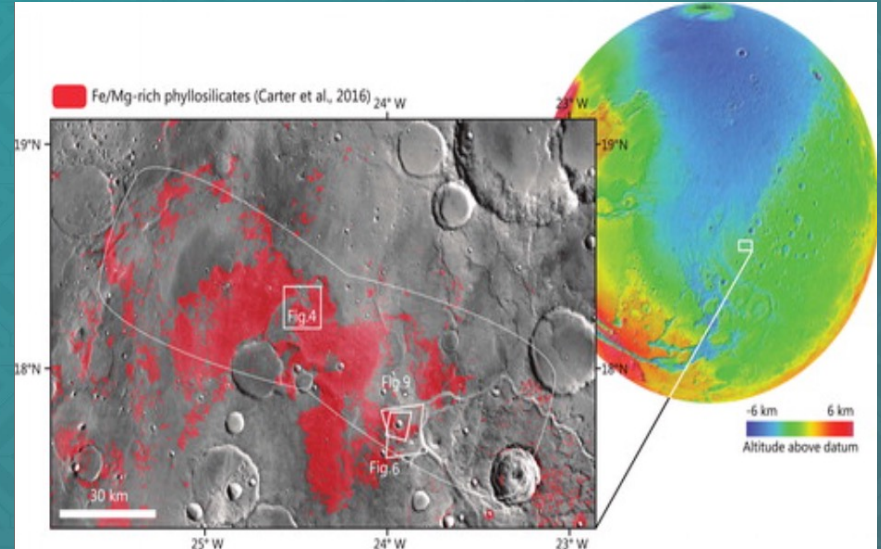
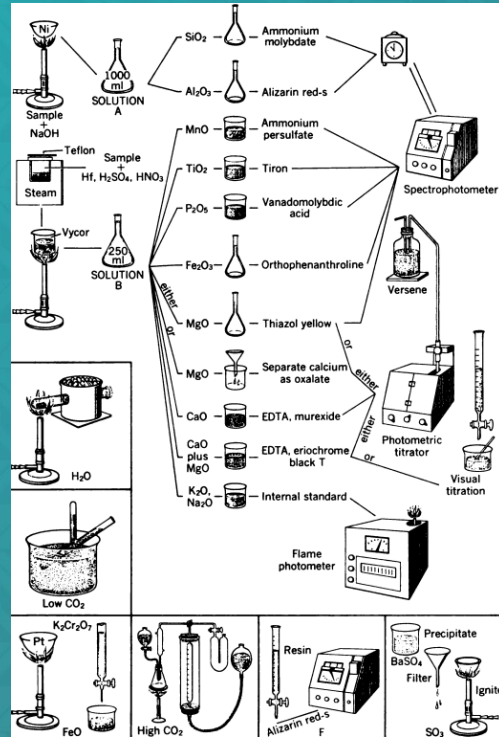

adastra

ROVER DESIGN

Science Payload:

Mortar grinders (mullite mortars) will be used during the preparation of the powder samples in the experimental phase.

While preparing the acid solution during the experiment, fume hood, water bath, Teflon beaker, steam bath, heater, Vycor beakers, hot plate will be used. While determining iron during the experiment, pipet, volumetric flasks, spectrophotometer will be used.

While determining magnesium during the experiment, volumetric flasks, spectrophotometer will be used.

The experiment will examine the rocks to be collected from Oxia Planum. Magnesium determination will be made from rock that is thought to contain silica. If the rock does not contain silica, magnesium detection may not be possible. Also, if the MgO concentration is about 2.4 percent or less, the photometric method is more suitable and therefore imaging with spectrophotometer may not be possible. However, the applicability of iron detection in rocks containing phosphate, silica and carbonate indicates that we can detect at least iron if it is present.

ROVER DESIGN

Ground station equipment and communication system:

The parts used are two EWS360APs (Indoor Engenius Access Point) and two GS108LPs (Netgear Unmanaged Network Switches). Access points are configured to create a WDS bridge between them with a frequency of 5Ghz to achieve higher bandwidth for video feeds. Also access points support 2.4Ghz wireless connection to clients as a way to configure the network wirelessly (Management network). After the interconnection between access points, both sides (Rover side and ground station side) connect to a wired local area network via the switches aforementioned.

The main reasoning behind choosing these components are the quality and availability of the components. These components have been used for numerous times before in similar applications and have proven themselves. After checking the specifications from the data sheets and considering the prices these components were the most fit for our circumstance. The reason we have used indoor access points instead of outdoor access points is they have been provided for free by our sponsors and were enough to create a reliable wireless network.

ROVER DESIGN

Ground station equipment and communication system:

We have chosen a pretty simple and commonly used system for achieving communication. Using multiple frequencies to handle different data streams such as control/sensor data and camera feeds may prove to be useful, but with the resources we currently have it would be unsound to create more than one network since it would increase the complexity and the cost of the components.

adastra

ROVER DESIGN

Ground station equipment and communication system:

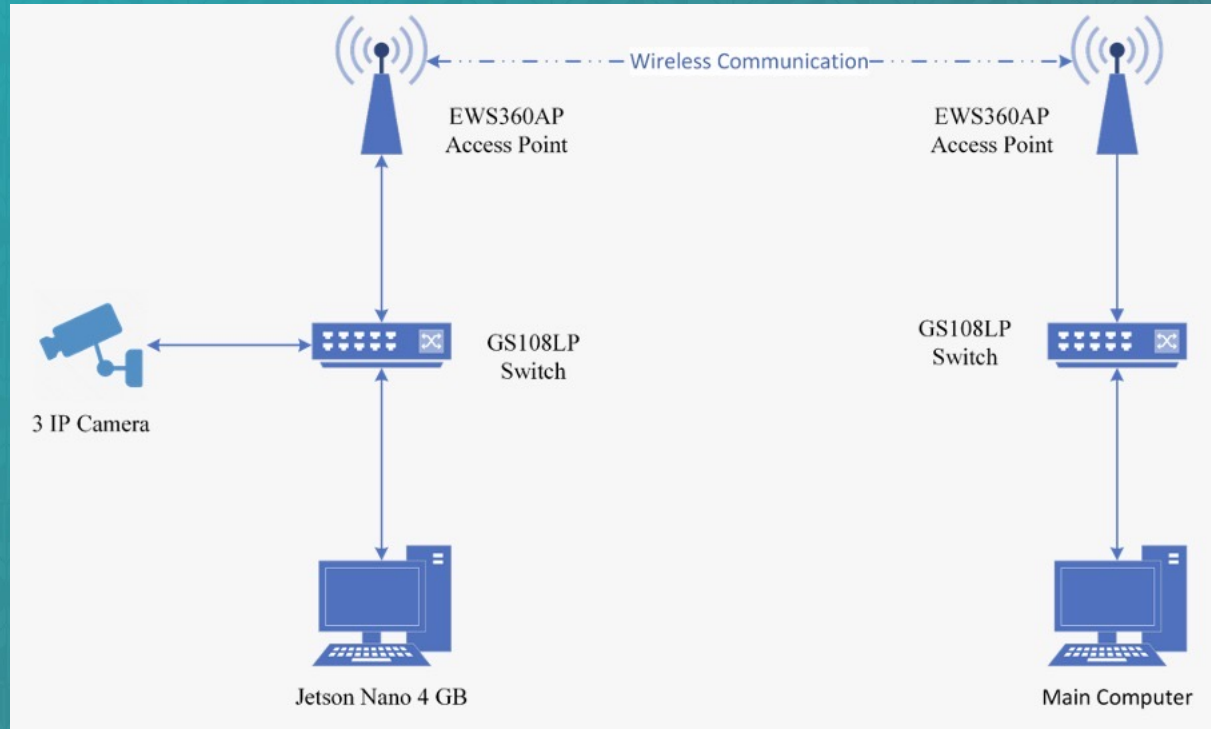

adastra

ROVER DESIGN

Ground station equipment and communication system:

EWS360AP (Access Point) is normally an indoor access point, but thanks to its high output power rated up to 29 dBm it provides excellent communication even in outdoor circumstances. The maximum range it provides could not be tested by us with a clear line of sight. Because even in an environment with wireless congestion at 25 meters it was still communicating with close to perfect signal. Besides APs stationed at ground station and the rover's body, both areas have a 8 port gigabit network switch used to create a cabled local area network between components.

Even though the provided access points are indoor they have been tested in similar environments to ARC and have provided great results. The switches have high quality gigabit ports and the cables used are electromagnetically shielded, therefore they are practically immune to noise or any kind of interference. If it all goes according to our tests this system will prove to be adequate.