

Anatolian Rover Challenge
2024 Manual



Version Information

This file is the ARC Manual v.3 released on 01.03.2024.

For the planned updates check **Change in Rules and Delivery Dates**.

Written by the ARC Committee. Digitally distributed.

Changelog

ARC'24 Manual v.1 is the first released version of the ARC'24

ARC'24 Manual v.2 is the second released version of the ARC'24

ARC'24 Manual v.3 is the last released version of the ARC'24

Information Channels and Contacts

The ARC website is the main source of information on the event.

Questions regarding the rules can be directed through the ARC website.

The ARC Website: www.anatolianrover.space

The ARC Mail Address: info@anatolianroverchallenge.com

Contact persons:

- 1. Utku Hatipođlu**
ARC General Manager
- 2. Iřık Su Yazıcı**
ARC Rules Manager & Head Judge
- 3. Nisa Tutku Topđu**
ARC Rules Assistant Manager





Table of Contents

Table of Contents	3
1. Introduction	6
2. General Information	7
2.1. Descriptions	7
2.2. Participation Conditions	7
2.3. Calendar	8
2.3.1. Milestones	8
2.3.2. Details	8
2.4. Emergency Handling	9
2.5. Challenge Fee	9
2.6. Questions and Answers	9
2.7. Change in Rules and Delivery Dates	9
2.8. Finalists	10
3. General Rules	11
3.1. Rover Design Requirements	12
3.1.1. Weight Limitation	12
3.1.2. Size Limitation	12
3.1.3. Cost Limitation	12
3.1.4. Design Advice	12
3.1.5. Rover Safety	13
3.1.5.1. Activity Light	13
3.1.5.2. Emergency	13
3.1.5.3. Use of Flammables-Explosives	13
3.1.6. Communication Equipment Usage	13
3.2. Penalty Conditions	14
3.3. Objection Process	14
3.4. Ethics	15
4. Definitions	15
4.1. Challenge Area	15
4.2. Mission Fields	15
4.3. Rover	16
4.4. Bases	16
4.5. Base Crew	16
4.6. Field Crew	17
4.7. Judges	17
4.8. Intervention	17
4.9. Field Onboarding	18
4.10. Skipping	18
4.11. Field Dimensions	18
4.12. Coordinate System	18
4.13. Border Violation	18
4.14. Criteria for "Reaching Target"	18





5. Documentation	19
5.1. Application Form	19
5.2. Reports	19
5.2.1. Design Report	19
5.2.2. Science Report	19
5.2.3. Cost Report	21
5.3. Video Presentation	21
6. Background of the Missions	22
6.1. Mars Story	22
6.2. Moon Story	22
7. Missions	23
7.1. The Final Stage Missions	23
7.1.1. Mission 1: Science Sampler	23
7.1.1.1. Mission Steps	23
Part 1 Landing & Exploration (30 min)	23
Part 2 Laboratory (15 min)	24
Part 3 Presentation (10 min)	24
7.1.1.2. Mission Details	24
Part 1 Landing & Exploration (30 min)	24
Part 2 Laboratory (15 min)	25
Part 3 Presentation (10 min)	25
7.1.1.3. Bonus Scores	26
7.1.2. Mission 2: Autonomous Exploration	26
7.1.2.1. Mission Steps	26
7.1.2.2. Mission Details	27
7.1.2.2.1. Rover Satellite Communications - Client Module	27
7.1.2.2.2. Message Format: Rover Satellite Communications Protocol	27
7.1.3. Mission 3: Lunar Robotic Prospector	30
7.1.3.1. Mission Steps	30
7.1.3.2. Mission Details	31
7.1.4. Mission 4: Night Launch	32
7.1.4.1. Mission Steps	32
7.1.4.2. Mission Details	33
7.2. Side Missions	33
7.2.1. Challenge to Shine	33
7.2.2. Side-Challenges	34
7.2.2.1. Rover's Mystery Canvas	34
7.2.2.2. Victoria's Rover	34
7.2.2.3. Disco Rover	34
7.2.2.4. Rover Treasure Hunt	34
7.2.2.5. Rover Jenga	34
7.2.2.6. Egg and Rover Challenge	34
7.2.2.7. Nascarover	34
8. Technical Details	35
8.1. Sample Tube & Rocket	35





8.1.1 Sample Tube Sketch	35
8.1.2 Rocket Sketch	36
8.2 Repeater	37
8.2.1 Repeater Sketch	37
8.3 Mining Cart (MC)	38
8.3.1 MC Sketch	38
8.3.1.1 Mining Cart	39
8.3.1.2 Pins	39
8.3.1.3 Slider	40
8.3.1.4 Lever	40
8.3.1.5 Handwheel	40
8.3.1.6 Container & Lid	41
8.3.2 MC Steps:	41
8.3.3 MC Details:	42
8.4 Resource Extractor (RE)	42
8.4.1 RE Sketch	42
8.4.2 RE Steps:	42
8.4.3 RE Details:	42
8.5 Fuel Cell	43
8.5.1 Fuel Cell Sketch	43
8.5.2 Fuel Cell Steps:	43
8.5.3 Fuel Cell Details:	43
8.6 Marker	44
9. Score Tables	44
9.1. Final Qualification	44
9.1.1. Design Report	45
9.1.2. Video Presentation	47
9.1.3 World Rover League	48
9.2 Finals Scoring	48
9.2.1. Mission 1: Science Sampler (Mars Field)	48
9.2.2. Mission 2: Autonomous Exploration (Moon Field)	51
9.2.3. Mission 3: Lunar Robotic Prospector (Moon Field)	52
9.2.4. Mission 4: Night Launch (Mars Field)	53
9.2.5. General Scoring for All Missions	54



1. Introduction

Anatolian Rover Challenge is an annual international **rover** challenge. In the scope of the challenge, the teams of students that are affiliated by academic institutions try to achieve the determined missions by their own "planetary exploration robots" called **rovers**. Teams should design, manufacture, and equip their **rovers** with the necessary abilities to complete all missions. The ARC event aims to create an opportunity for teams to show their abilities in solving difficult engineering and scientific problems.

The student teams that apply for the challenge go through a design report and video presentation process. After the evaluation, teams that qualify for the finals are announced and invited to participate in the field evaluation that takes place in Türkiye.

The finals are held in the carefully designed open field that is 40-meters in diameter and designed to resemble the surface of Mars and Moon. During the finals, teams perform four mission scenarios. Scores are determined by **judges** based on score tables. ARC begins with a meetup day, continues with three days of competition, and ends with an award ceremony.

ARC '24 is the third edition of the rover competition series by UKET and a member of World Rover League. In the last edition, ARC '23, the winner team is awarded their photo to be **launched to space!** It will decorate the walls of the International Space Station on the postcard represented below. On January 17th 2024, the first Turkish astronaut, Alper Gezeravcı, flew the postcard on his mission (Ax-3) to the ISS. More information on the mission is on the ARC website. Godspeed!



2. General Information

Anatolian Rover Challenge (ARC) 2024 will be held in July 2024. The challenge is organized by the ARC Organizing Committee (or the ARC Committee) which is a subcommittee of the Space Exploration Society (UKET) established to contribute to space studies in Turkey.

2.1. Descriptions

Supreme Board of Judges: The responsible committee for the examination and scoring of the reports and missions throughout the challenge, which is established on transparent principles, with international participation.

Organizing Committee/Organizer/The ARC Committee: The ARC Organizing Committee is a subcommittee of the Space Exploration Society (UKET). It is the committee that conducts and manages all the organizational processes of the **Anatolian Rover Challenge**.

Team: A group of students that are affiliated with an academic institution and applied for the challenge. Each team must consist of at least two members and an academic advisor.

Team Leader: The responsible person for matters related to the team and the **rover**.

Team Member: A team member must be over the age of 18 and a university student of all levels. Members can take part in only one team.

Advisor: The person with an academic title that guides the team.

Prohibited Substance: Substances that affect self-control, team members, and the **rovers**, such as alcohol, drugs, all kinds of weapons, etc.

Finals: The on-stage challenges (explained in the **Missions** section in detail) that are held in Türkiye. Only teams that are qualified and announced as finalists can participate in the finals. Teams that are not eligible for the finals or curious are encouraged to experience the challenge as visitors.

2.2. Participation Conditions

1. The application for the challenge is required to be submitted electronically using the online application system at the [Apply ARC | Anatolian Rover Challenge](#) address.
2. It is obligatory to participate in the challenge as a team, individual applications will not be accepted. There can be more than one team from a single institute.
3. In case of any changes in the information given in the application, the teams must notify the **Organizing Committee**.
4. Each team is required to have a **Team Leader** and an **Advisor**, whose descriptions are given in the **General Information** section.
5. The deadlines for the reports and events are specified in the challenge calendar. The **Organizing Committee** reserves the right to change the calendar.
6. Only the team members must be the authors of all the required documents that will be submitted.



- An academic advisor is required for all teams. The teams may have more than one academic advisor.

2.3. Calendar

2.3.1. Milestones

An up-to-date calendar of the challenge and important dates are shown in the table below. It should be kept in mind that the versions of the ARC Manual will slightly differ with regard to a few additional details. The missions will remain intact.

Date	Event
01.01.2024	Release of the ARC'24 Manual v.1
12.01.2024	Online 1st Q&A with the teams
01.02.2024	Release of the ARC'24 Manual v.2
01.03.2024	Release of the ARC'24 Manual v.3
01.03.2024	Start of the Application Submission
01.03.2024	Start of the Design & Video Report, Science Report, and Cost Report Submission
Last week of March 2024	Online 2nd Q&A with the teams
01.04.2024	Early Application Due Date
01.05.2024	Late Application Due Date
01.05.2024	Design & Video Report, Science Report, and Cost Report Submission Due Date
20.05.2024	Announcement of the Finalists
01.06.2024	Last release of the communication protocol
17-21 July 2024	ARC '24 Field Challenges in Türkiye

2.3.2. Details

- The deadline for applications is the same as the **Report** submission due. After this date, applications will be invalid and will not be considered. Teams that apply early may be given priority in the challenge day timetable.





2. Registration for the finals will be performed on-site on the stated dates.
3. On the closing day, the teams' total scores will be calculated and announced, and awards will be given to the top teams.
4. The first version of the timetable including the exact time slots for each mission will be announced by the **Organizing Committee** one week prior to the event, while the final version will be announced on the first day of the challenge.
 - a. Each team is responsible for complying with this timetable. **The Supreme Board of Judges** reserves the right to reject any request for change in the challenge day timeline.

2.4. Emergency Handling

1. Necessary precautions and disaster plans have been made for the safety of the teams and the challenge area. Teams are expected to comply with the safety instructions from the **ARC committee** on site.
2. In case of any injuries, the first aid will be made by paramedics and if necessary, the injured person will be sent to the nearest hospital by an ambulance. By applying for the ARC, teams will be considered as accepting the necessary emergency actions by the **ARC committee**.

2.5. Challenge Fee

The early submission fee is 125 US Dollars, which should be paid by 01.04.2024. For the applicants who submit their fee after this date until the last day of submission of applications which is 01.05.2024, the late submission fee is applied which is 150 US Dollars.

Teams that qualify for the finals must send the challenge fee of 125 US Dollars after the announcement of the finalist **teams**. The payment details will be specified on the website.

2.6. Questions and Answers

A frequently updated **Questions and Answers** section is provided on the website. Teams are encouraged to ask questions through this section. The Q&A section **overrides the** ARC Manual. In addition, teams can also use the forum page (<https://www.anatolianrover.space/forum>) on the website to share with each other.

2.7. Change in Rules and Delivery Dates

The **Organizing Committee** reserves the right to extend the deadline for document submissions and make necessary but unavoidable corrections to the challenge regulations at any time. Teams are obliged to check the challenge website for any changes. Major changes in rules are stated through the versions of the manual:

- 01.02.2024 – the ARC Manual Version 2 (v.2.)
- 01.03.2024 – the ARC Manual Version 3 (v.3.)





2.8. Finalists

The finalist teams will be selected by the **judges** based on the reports submitted by the teams. The finalists will be announced on the date specified in the schedule.





3. General Rules

The general rules are listed below:

1. All the teams present in the on-site challenge will be given a certificate of participation.
2. Rewards will be given according to the ranking of the scores collected from missions.
3. The academic advisor's job is to help students plan their projects, guide them academically, and support them mentally and emotionally. The awards to be given at the end of the challenge are only for the team members.
4. The teams are obliged to show the expected care for their surroundings and other teams while competing.
5. "Waiver form" will be read and signed by each team member before the challenge during the registration.
6. All team members are obliged to comply with the rules specified in this specification. If non-compliance is observed by the **Organizing Committee**, the relevant situation will be brought to the attention of the **Supreme Board of Judges**. As a result of the evaluation of the **Supreme Board of Judges**, individuals or teams may be disqualified from the challenge.
7. During the entire event, no **rover** or any part of the system of the **rover** may damage or interfere with other teams' systems. Any reports of such violations will be investigated independently by the judges or organizers, and any violation of this rule may result in the team's disqualification from the challenge. The **Organizing Committee** will not be held responsible for any of the damage caused to teams' systems.
8. Teams and members are fully responsible for any damage, accident, situations, events, etc. caused by their hardware/software. All the precautions and rules declared by the **Organizing Committee** must be strictly followed. Any violation of safety regulations and standards will result in the disqualification of the team from the challenge.
9. The use of any **Prohibited Substance** during the challenge is prohibited and constitutes a crime under the laws of Türkiye. Persons/teams who use and disturb the environment will be disqualified from the challenge.
10. In case of a dispute regarding the challenge, the decision of the **Supreme Board of Judges** will be considered binding.
11. In case of violation or cheating of the rules or specifications, action will be taken by judges.
12. Teams must comply with the directions and instructions of the **Judges/Organizing Committee**.





3.1. Rover Design Requirements

In order to participate in the challenge, the general requirements specified in this file must be met. Teams have to indicate in their technical reports that they meet these requirements. In exceptional cases where teams are unable to meet the general requirements, they should contact the ARC **Organizing Committee** before submitting the technical report. In the case of any violation in requirements, the organizer has the right to remove the team from the challenge.

3.1.1. Weight Limitation

The weight limitation applies only to the rovers and does not include fixed antennas, computers, and other equipment. The rover will be weighed at the start of each mission.

1. The **rover's** weight with **installed systems** should not be more than 60 kilograms.
2. **Rovers** over 60 kilograms will receive 5% penalty points for each kilogram weighing more than 60 kilograms.
3. The total weight of the **rover** and installed mission-specific hardware in all missions combined must not exceed 80 kilograms.

3.1.2. Size Limitation

The size limitation applies to the **rovers** including **installed systems**. The missions of the challenge are designed for a 1.5m x 1.5m x 1.5m vehicle, with at least 30 degrees of slopes, the large-scale **rovers** might not pass the expected passages in the missions, and might not complete the missions. If a **rover** cannot exit/enter the airlock, it can start from outside of the airlock for a 30% penalty.

3.1.3. Cost Limitation

The total cost of the **rover** systems cannot exceed 20,000 US Dollars (see **Cost Report**).

3.1.4. Design Advice

Rover should be designed by considering the climate and environmental conditions of the region where the challenge is held. Any damage that may arise from environmental conditions is the responsibility of the relevant team. During the missions, **rovers** will work in the open field, and the challenge plan may be rescheduled in very windy, rainy, or foggy weather conditions. It is the teams' responsibility to design or maintain their vehicles and equipment in such a way that they will not be affected by environmental conditions, during or before the challenge.

The challenge **fields** will be prepared by taking the surfaces of the planets on which the scenarios take place as examples. It is recommended that **rovers** be designed to perform the missions given in ground conditions such as gravel, either loose or hardened soil, fine particle sand. There will be cratered or sloped sections in the field.





Standard European type 220-230 V 50 Hz AC F type socket will be provided to the teams at the **bases**. In addition, facilities such as tables, chairs, and extension cables will be provided at the **base**.

3.1.5. Rover Safety

3.1.5.1. Activity Light

Rover should be able to show its operational status to **judges** in proximity with a light that turns green when remotely controlled, yellow during autonomous control, and red to indicate disarm. If the activity light is not turned on during the missions, the **rover** incurs a 10% penalty.

3.1.5.2. Emergency

Rovers must not cause electrical, thermal, or mechanical harm to people who might want to stop it or to the people around them. The **field crew** of a relevant team is responsible for this. Teams are liable for damage caused by their **rovers** and activities while on and off the mission.

1. A red emergency button with a diameter of at least 3 cm should be available on the **rover**, and this button should be kept in a visible place. Otherwise, the teams will not be allowed to start the mission. The emergency button must stop the transmission of power to all the **rover's** moving systems. The **rovers** without an emergency button are subjected to a 5% penalty.
2. There is no limitation on the **rover's** cruising speed. Apart from the mission, the relevant teams must control their **rovers**, taking into account the safety of the living creatures in the **challenge area**.

3.1.5.3. Use of Flammables-Explosives

When teams want to use pyrotechnic systems, they must contact the **judge** before the challenge and provide the associated MSDS documents.

3.1.6. Communication Equipment Usage

Teams can communicate between the **rover** and the **base** using a radio link. It is necessary for the success of the challenge missions that the communication systems of the teams cover the challenge area.

In the **challenge area**, teams will set up their equipment in the **base**. They can place the antenna outside so that their communication equipment is next to the **base**. Teams will be settled in the **bases**, so the need is at least 10 meters of cable for their communication antennas. Teams will be shown a certain area near the **base** to put their antennas. Antenna masts cannot exceed 3 meters in height and the area might not be supportive for masts that are not strongly anchored as it is composed of loose soil.





During the challenge, teams are free to choose communication bands and equipment. For this reason, planning should be done considering the field can be approximately 40 meters in diameter. It is recommended that the communication equipment can work in the same environment as the surrounding wireless devices.

During the challenge, the equipment can be used by the law numbered 5809 of the constitution of the Republic of Türkiye. For the frequency bands available for use, the table below is recommended to be examined.

<https://www.btk.gov.tr/uploads/undefined/mfp-01-02-2019.pdf>

It is the team's responsibility to operate the communication systems within the legal power and frequency limits.

3.2. Penalty Conditions

People or teams that do not comply with the conditions specified in the General Rules and Ethical Rules will be evaluated by the **Supreme Board of Judges**. If deemed necessary, individuals or teams are asked to defend themselves. As a result of the evaluation, penalties such as deduction of points, failure of the mission, or disqualification from the challenge may be given. On discompliance, the **Supreme Board of Judges** can deduce the scores of the team.

3.3. Objection Process

1. The pre-challenge objection process works as follows:
 - Prior to the challenge, address venue or rules concerns in writing via the specified website; report evaluation objections should be submitted in writing to the **Organizing Committee** via the provided email, and the **Organizing Committee** will forward these to the **Supreme Board of Judges** for examination.
2. During the challenge, the objection process works as follows:
 - a. Teams are allowed to object to the decisions taken by the **judges**, for review by the **Supreme Board of Judges** consisting of all **judges**.
 - b. Video recordings taken by the **Organizer** during the challenge preparation and mission are used as evidence for objections.
 - c. Each team has a maximum of 3 objection rights.
 - d. Objections including possible proof must be delivered by the team leader via an email to the address: **rules@anatolianroverchallenge.com**.
 - e. The **Supreme Board of Judges** will announce the results of the objection evaluation at the latest before the challenge award ceremony.
 - f. Any questions during the challenge will be addressed by the relevant **judge**. Teams can not object to a third person.





3.4. Ethics

1. Any kind of inappropriate behavior will be noted by the **Organizing Committee** and related authorities will also be informed immediately if necessary.

These behaviors can be summarized as follows;

- a. Insulting, swearing, threatening, etc. actions against other teams, people, or organizations through social media or in the **challenge area** during the challenge period.
 - b. Physical, verbal provocation, etc. movements towards other competitors during the challenge.
 - c. Behaviors that may disturb other teams in and around the **challenge area**.
 - d. Being involved in fights in the **challenge area**.
2. Language, religion, belief, political opinion, race, age, and gender discrimination will not be tolerated in the **challenge area**, as well as behaviors and practices that may jeopardize equal opportunity.

4. Definitions

4.1. Challenge Area

The challenge takes place in two separate fields: Moon Field and Mars Field. The Mars Field is home to Missions 1 and 4, while the Moon Field is home to Missions 2 and 3.

4.2. Mission Fields

The areas where the missions will be performed in the **challenge area** will be referred to as the "mission field". During the challenge period, only the field crew of the relevant team, the **rover** of the relevant team, and the **judges** can enter the **mission fields** and interfere with the field and the **rover**. Besides, watching the **mission fields** while other teams are competing will not be allowed.

Mission fields will be overhauled for the next relevant team by the **judges** at the end of each mission. **Judges** can make changes to the field to ensure equality during the mission.

Weight and size checks are made near the **field** where the **rovers** begin their preparations for the mission.

There are two **mission fields**:

Mars field: Includes **Mars Base** and resembles Mars surface by its color and features.

Moon field: Includes **Moon Base** and resembles Moon surface by its color and features.



4.3. Rover

Rover is a mobile device that can operate alone, without any physical connection with another system, and can be composed of various subsystems. **Rover** can only be commanded from the **base** or can move on its own (autonomous).

4.4. Bases

There are two **base** replicas in the **challenge area**, one on each **mission field**. Competing teams will control their **rover** within the **bases** during the missions.



They are closed areas that are located in the **mission field** and connected to the rest only by an "airlock". Only the **base crew** of the relevant team and the **judges** can enter the **base**. The **base crew** can only control the **rover** remotely (via remote-wireless connection). During missions, the **base crew** will not be able to see the **rover** directly. The relevant team must install the necessary equipment and antenna connections to the **base** to control the **rover** before starting the mission. Before each mission, teams will be given some specified time for preparation according to the challenge timetable.

4.5. Base Crew

It is a crew, formed by selecting among the team members with a maximum number of 8 members, that is the only authorized and responsible crew to remotely control the **rover** in the **base**. The **base** team cannot communicate with the outside except the **rover** and **judges** during the mission. The **base crew** starts and finishes commanding the **rover** by the **judges'** directions to accomplish the mission. During the autonomous driving stages, the **base crew** must comply with the instructions and the directions of the **judges**. If **base crew** members leave the **base** when necessary, they cannot return to the **base** before the current mission is finished. That team member can only be a **field crew** or a spectator. The **base crew** may decide not to continue the



mission. Until the decision is taken, they are considered to have completed the mission without losing their scores.

4.6. Field Crew

It is a crew consisting of a maximum of 4 selected members of the relevant team who can observe the **rover** in the field of mission, during the missions. The crew is responsible for the preparation of the **rover** in the field of mission, decisions on whether to intervene when necessary, and responding to the **rover** in emergencies. The **field crew** should not voluntarily enter the camera view of the **rover** during the mission. In the case of doing that by mistake, they should standstill. It is forbidden for the **field crew** to make hand signals or speak during their mission, except in emergencies and interventions. **Judges** may dismiss the **field crew** from the field of mission without giving any reason.

4.7. Judges

The **judges** are the most authorized officials in the challenge. It is essential to pay attention to and follow the instructions and directions of the **judges**. During the challenge, there will be at least one **judge** at each of the places like the **base**, the field, and around the **challenge area**. The **judges** are responsible for the organization of the challenge and guiding/assisting the relevant team.

4.8. Intervention

During the mission process, the crew or one member of the **field crew** may decide to intervene. They are required to notify the **judge** of these decisions before implementing any change. In cases where the safety of the living things in the field is at risk, as a result of a malfunction in the **rover** or the conscious control of the **base crew**, the **judges** may decide to intervene by pressing the **rover's** emergency button. Mission time will not be paused when **intervention** begins. During the **intervention** on the **rover**, there is no limitation for the number of team members on the field. When the **intervention** is over, the general **field crew** rules are applied. The remaining team members should join the spectators. Only the **field crew** and **judges** can approach the **rover**, and the communication between the **base crew** and the **field crew** is made only one way through the **judges**. For each **intervention**, scores are deducted from the relevant team for that mission, as indicated in the Score Table. During a mission, the **rover** can be interfered with at most 3 times. When the 4th **intervention** is performed, it is assumed that the team has decided not to continue the mission, but is allowed to use the time remaining for testing purposes. During the **intervention**, changes that will critically affect the **rover's** functionality or relocation of the **rover** in such a way as to gain an unfair advantage in mission steps will be rejected by the **judge's** decision. As **teams** are allowed to bring their **rovers** back into the **base**, interferences in the airlock except modifying the rover's functionality will not be considered as an **intervention**.





4.9. Field Onboarding

The day before missions begin, teams will be toured the fields in groups. **Judges** will explain each mission step to the team members and will answer their questions first hand on-site.

4.10. Skipping

Teams can skip the steps they want by informing the **judge**. They are not penalized by time or scores for the steps they skip; in case of **skipping**, mission time will not be paused. If a team does not use their right to skip, they must take each mission step in order, without **skipping**. In case of a skip, the **judge** can make the necessary changes on the field and on the rover, such as the arrangement of the position so that the next mission steps are not adversely affected. While the **judge** makes the necessary changes, it is forbidden to touch or intervene in the vehicle by any team member, and it is going to be considered **intervention** unless specified in the rules. The skipping rules specific to missions are as follows:

Mission 1: Skipping applies, teams can decide to try again the skipped step.

Mission 2: Skipping is only allowed for the stages i.e., **Tool Delivery**, **Lava Tube exploration**, and **Return to the base**. Teams cannot skip a step in this stage, the whole stage should be skipped. For instance, if the Lava Tube stage is decided to be skipped, steps 6-8 should be skipped entirely.

Mission 3: Each step can be skipped, however, if skipped a step it cannot be retried.

Mission 4: Each step can be skipped, however, if skipped a step it cannot be retried.

4.11. Field Dimensions

Mars Field and Moon Field are approximately 40 meters in diameter, both sites have a circle shape. Coordinates of the center point of the fields can be provided before the missions.

4.12. Coordinate System

WGS-84 coordinate system and (Lat: dd.dd., Long: dd.dd.) format will be used when locations are given or requested. Ex: (41.100276, 29.020975).

4.13. Border Violation

If the **rover** goes off-site, the **intervention** rules apply and the **field crew** brings the **rover** back into the field.

4.14. Criteria for “Reaching Target”

Measurements will be used to score points in mission steps that include expressions such as "goes/returns near the target". The distance between the outer surface of the target object and the **rover's** closest point to this surface is measured, if it is less than the asked distance (this





distance is 2 meters for **Mission 2** and 1.5 meters for remaining unless otherwise stated), the **rover** is considered to **approach** or **arrive**. For example, to **go near/reach** the **base**, it is accepted that there is a part of the **rover** within the specified distance from the outer surface of the **base**.

5. Documentation

5.1. Application Form

Every team must complete the challenge application form on the official ARC website. Teams must provide team information that includes “team name”, “list of the team members”, and “the contact information of the team leader and the team advisor” to the **Organizing Committee**. Teams that do not present the complete team information before the design report submission due, will not be allowed to participate in the challenge. After the application is completed, all team members must join the ARC Community Discord server. During the competition, all communication will happen through Discord (See: *discord.com*).

5.2. Reports

5.2.1. Design Report

To become a finalist and participate in the challenge, the candidate teams must report their work and electronically send the report together with the video they prepared, as specified on the challenge website, within the dates specified in the challenge calendar. The Design Report will be uploaded for public view after finalists are announced. The report must be prepared using the given template on the ARC website. Expected contents and scoring parameters are stated in the **Score Tables** section. This score combined with the video presentation score to be used for ranking the teams to select finalists.

5.2.2. Science Report

The **Mars field** will be designed based on the Nili Fossae (21.3°N, 74.1°E) on the surface of Mars. From the given Mars coordinate, a scientific question should be determined to be investigated. This hypothesis should be explained in the science report. To test the hypothesis, a landing point on the given challenge area sketch should be specified. This landing point is the position where the relevant team's **rover** will start Mission 1 during the challenge. While determining this starting point, two essential points should be considered. The landing point should be coherent with the scientific hypothesis as well as it should be a suitable terrain for the **rover** to drive.

The **Mars field** sketch representing the given coordinates is shown below. The teams should interpret the structures on the sketch based on the orbiter images of the Nili Fossae and by reviewing the literature. The selected structures from the Nili Fossae indicated in the sketch will



exist on the **Mars field** during the ARC finals. The structures in the **Mars field** will not be scaled versions of the real structures in the Nili Fossae. It should be noted that the maximum depth or height of the structures in the area can reach 2 meters, and the slopes of the structures can be 30 degrees.

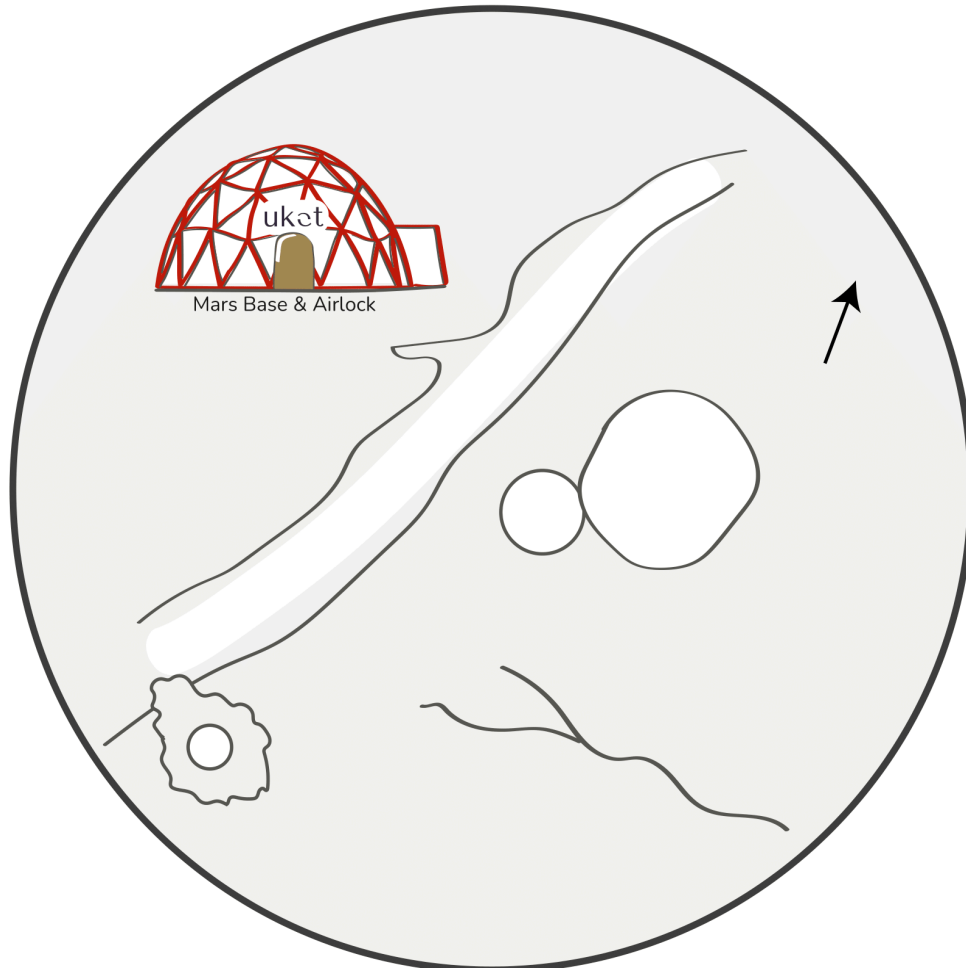

The report should also include which experiments were selected to check the scientific hypothesis that was determined. These experiments should be important in terms of checking the scientific hypothesis. Randomized experiments that do not contribute to the scientific hypothesis will not yield scores.

In this report, teams should indicate which scientific hypothesis they will test at the **designated area**, what kind of sample they aim to collect, what experiments they plan to perform on the sample, and what they plan to find as a result of these experiments. The hypothesis planned in the science report should be taken into account during the challenge. The points of Mission 1 will be affected by the **Science Report**. Following a different hypothesis than the one stated in this report during the challenge will result in a score break. The report must be prepared using the given template on the ARC website.



5.2.3. Cost Report

Teams are obliged to write a report on the cost of their **rover**. The total cost of the **rovers** cannot exceed 20000 US Dollars. The cost report template will be shared with teams on our website. All the details on the template should be fulfilled by the teams, and there should be at least 30 expense items of the **rover**. All the provided information must be provable with official documents on the challenge day upon request. The financial report is mandatory to participate in the final stage of the competition. In addition, the reports will be scored and the team with the best report will be awarded.

5.3. Video Presentation

Participating teams should prepare a video in which they show their **rover's** readiness for the challenge. The video link must be uploaded to the website of the challenge together with the report, at the latest on the report submission date. The video must be shared by the participating team on a constantly accessible service (YouTube is recommended) without any access restrictions. The purpose of the video is to show the team and the **rover's** compliance with the challenge regulations and how ready they are to obtain scores from the missions. The uploaded videos will be scored by the **judges** according to the criteria stated below. The video will be scored by the first 10 minutes. The suggestion of the **ARC Organization Committee** for the content duration is 6 minutes. Recommended content in the video and scoring is stated in the **Score Tables** section. Also, Video Presentations from previous challenges can be found on the ARC Website "Participants" section.



6. Background of the Missions

6.1. Mars Story

In the not-so-distant future, Earth launched a groundbreaking mission to Mars. Initially designed for exploration, the rover's capabilities were expanded to include the daring task of both investigating the Martian surface and returning with collected samples. With its advanced instruments, the rover meticulously explored the Red Planet, revealing intriguing geological features and gathering samples that held the potential key to Mars' history. Modified for the return journey, the rover navigated the Martian terrain with precision transferring the precious samples to a spacecraft bound for Earth. As the spacecraft entered Earth's atmosphere, scientists anxiously awaited the safe return of the Martian samples, marking a historic milestone in human exploration and deepening our understanding of the mysteries concealed within the rust-hued landscapes of Mars.

Under the Martian night, the rover received a vital mission: prepare a rocket loaded with Martian samples for its journey to Earth. Guided by commands from a team of astronauts, the rover activated launch pad floodlights for an inspection. The rover scans the rocket's surface for defects, ensuring all systems are optimal. The rover takes photos for a final check, examining the hull, solar panels, and antennae. The rover then proceeded to inspect the rocket's onboard computer and returned to base. In the control center, the rover team relayed the success of the mission. The rocket, now ready for departure, carried the promise of unlocking Martian mysteries in the sample container as it ventured back to Earth.

6.2. Moon Story

A team of astronauts from various space agencies have landed on a promising lunar area rich in water ice and aluminum compounds. They are conducting a 15-day mission on the sunlit side, setting up a temporary dome-shaped 6-meter lunar base. The mission involves studying long-term effects, experimenting with in-situ resource extraction, and learning to extract resources from moon regolith. Autonomous robots survey the lunar surface for useful ores and explore lava tubes. When a promising mining location is identified, a remotely controlled robot deploys a self-drilling ore mining cart. After collecting resources, a rover transports them to the base for analysis and extraction in a specialized oven instrument. The mission's success hinges on extracting the intended resources to a specified amount, with the goal of establishing a permanent lunar base next year. This base will utilize moon resources for infrastructure and energy, evolving into a colony in subsequent years.

7. Missions

7.1. The Final Stage Missions

7.1.1. Mission 1: Science Sampler

Time Limit: 30 minutes + 15 minutes + 10 minutes

Mission Field: Mars

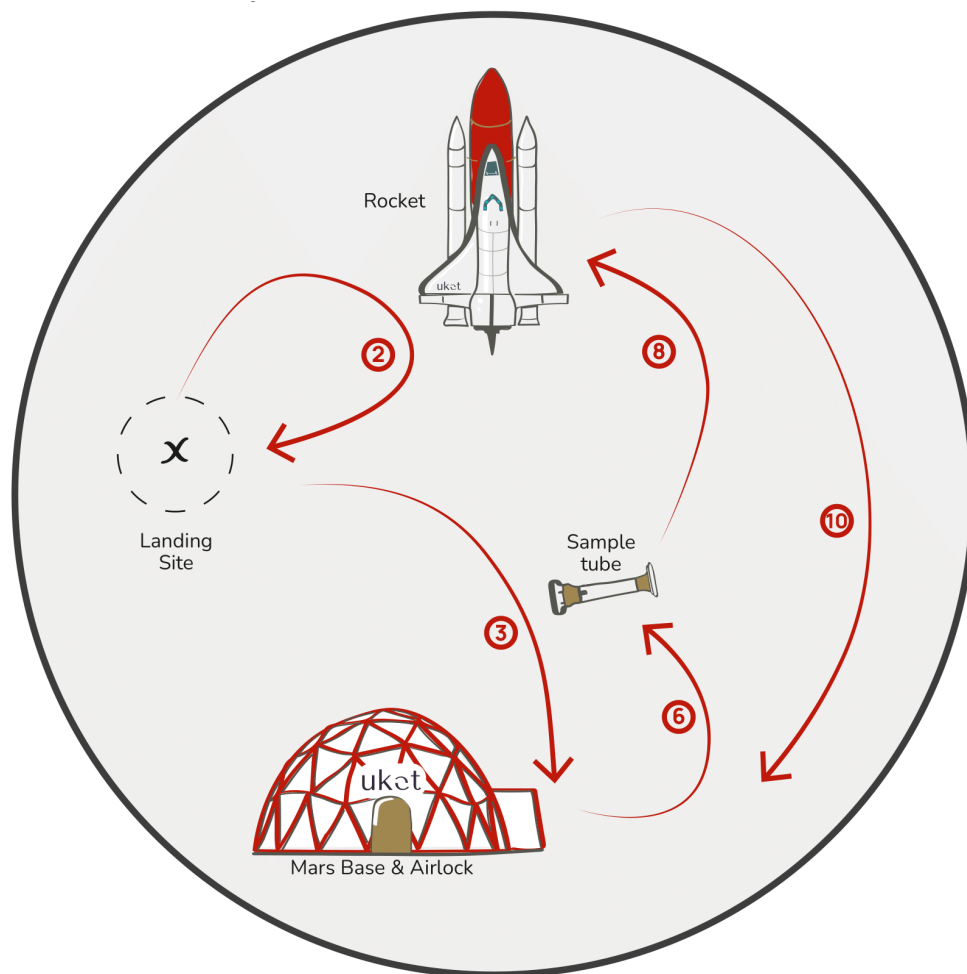

7.1.1.1. Mission Steps

This mission consists of 3 main parts:

Part 1 | Landing & Exploration (30 min)

1. The mission starts from the **designated area**.
2. The area is surveyed, and the soil samples are collected.

During the sample collection process,

- panoramic photographs of the area
- photographs of the sampling site



- any onboard measurements should be taken.
3. The **rover** navigates to the **Mars Base**.
 4. After reaching the **Mars Base**, the **rover** enters the **base** through the airlock.
 5. The taken sample in its sealed container is handed over to the **judges**.
 6. The rover navigates to the previously dropped **sample tube**.
 7. The **rover** collects the previously dropped **sample tube** from the ground.
 8. The **rover** carries the **sample tube** to the rocket.
 9. The **sample tube** is inserted into the rocket.
 10. The **rover** navigates back to the **Mars Base**.

Part 2 | Laboratory (15 min)

1. Astronaut scientists conduct their experiments.

Part 3 | Presentation (10 min)

Teams should be consistent with their Science Report. Science Report points will apply to this part.

1. The selection of the starting point of the **rover** in this mission is explained.
2. Photos taken during the mission are shown.
3. The sampling location is indicated, and the photographs taken while sampling are shown.
4. The results of the sample examinations are explained.
5. Stratigraphy of the region should be presented.
6. The results based on any measurements (such as sensors) should be explained.
7. Bonuses, if gathered during the mission, should be presented.

7.1.1.2. Mission Details

Part 1 | Landing & Exploration (30 min)

1. The **rover** starts the mission in the **designated area**, which is described in detail by the team in the **science report**. The **designated area** is shown to the field officials by the **judge**. The objectives given by the **judge** must be followed during the placement process. It should clearly be explained in the presentation part why this region was chosen for the test and what types of elements were considered, i.e. vitality, aquatic, or geological. It is important to conduct reconnaissance, consistent with the purpose outlined in the science report.
2. The soil samples are collected from the location deemed appropriate by the team. The sampling process requires the following:
 - The sample must be taken from a depth of at least 5 cm, with a minimum amount of 10 grams.
 - From the moment the sample is taken, it must be stored in an insulated, closed, and sealed container that will not be exposed to environmental effects to avoid contamination.

If any of these requirements are missing, it will not be counted as a full sampling process.

After landing, a 360° cylindrical or spherical panoramic photograph of the area is taken. At this stage, teams can collect visual data to support their hypothesis. The





location, where the sample is taken, should be photographed with a scale. It is necessary to explain the age relations of the geological units with each other by photographing them. The age relationship of the unit from which the sample was taken with the peripheral units is expected to be specified in the presentation part. For example, coordinate, time, and date information can be obtained in the area where the sample is collected; humidity and temperature measurements can be taken. The data obtained from the instruments, sensors, and photographs obtained at this stage should be explained in the presentation part.

3. The **rover** goes to the location of the **Mars Base** to deliver the sample and be prepared for the next phase of the mission.
4. The **rover** should fit into the **airlock**, and be able to climb up to 30-degree slopes.
5. The taken sample in its sealed container is handed over to the **judges**.
6. The previously dropped **sample tube** will stay on the ground. The **rover** should be able to get the **sample tube** from the ground. The **sample tube** material will be metal.
7. The **rover** carries the **sample tube** to the rocket.
8. The **sample tube** is inserted into the **rocket**. The detailed sketch of the **rocket** is provided in the **Technical Details** section.
9. The **rover** navigates back to the **Mars Base**.

Part 2 | Laboratory (15 min)

1. During the laboratory part, every team should follow the lab rules:
 - Teams are not allowed to bring heat installing (electrical, gas, or portable).
 - Teams are not allowed to bring flammable chemicals.
 - Strong chemicals ($4 < \text{pH} < 12$) are not allowed to bring more than 100 ml.
 - All chemicals and devices that will be used during the competition should be declared with a science report, if teams would not confirm their setup and chemicals before the competition they will not use during the competition.
 - Each team must bring a chemical declaration form before starting experiments. - this declaration will be signed by a judge and science team member.
 - Each team has to collect disposals before they leave the experimenting area.

Part 3 | Presentation (10 min)

Presentation template is provided at the ARC website. Please use the template.

1. A scientific question consistent with the hypothesis as indicated in the previously submitted report is expected to be investigated.
2. The geology of the area is specified using photographs. Observed geomorphological structures are interpreted.
3. The sample location must be consistent with the scientific hypothesis. It is also important that the photographs taken from the sampling area must be scaled.
4. Laboratory results of the collected sample should be reported.
5. The relative age relationships of morphological structures are explained.
6. Each sensor should be explained in terms of why they have been used. Results should be shown.



7.1.1.3. Bonus Scores

There will be a geological mystery in the Mars field. Teams should have a knowledge on the geology of Nili Fossae and Mars to identify it to get bonus points.

7.1.2. Mission 2: Autonomous Exploration

Time Limit: 30 minutes

Mission Field: Moon

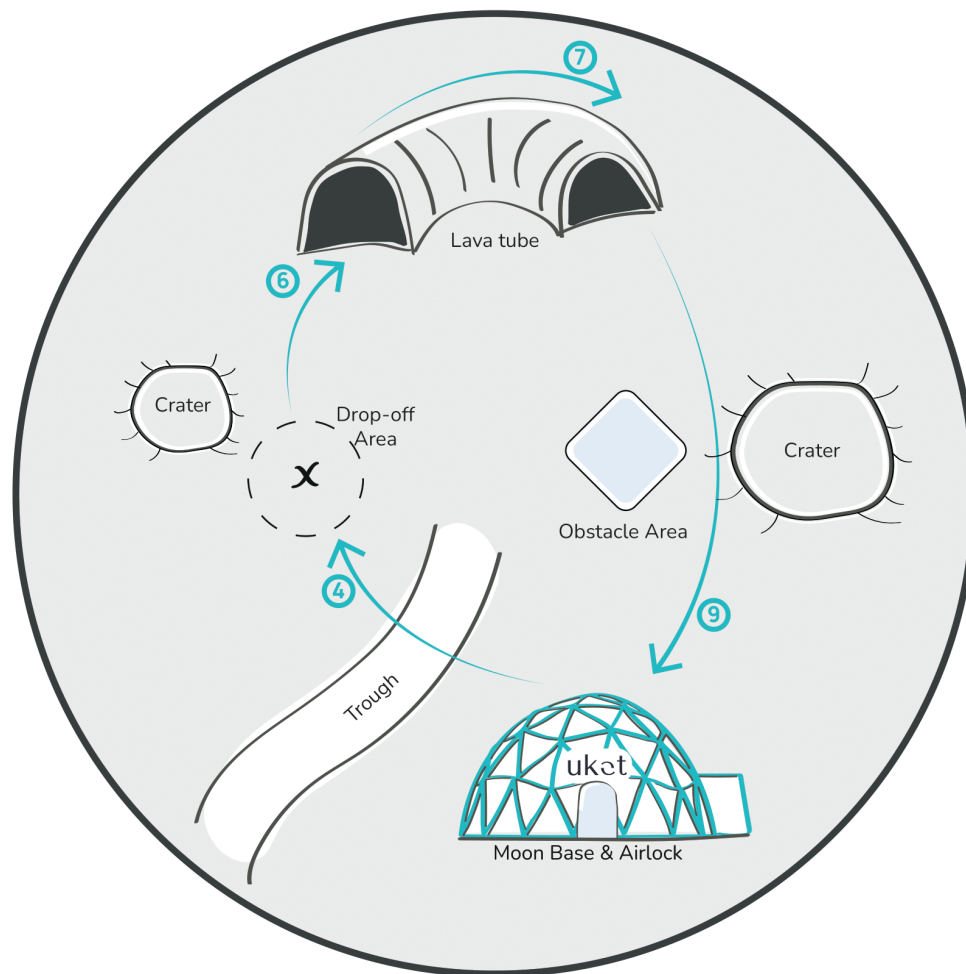

7.1.2.1. Mission Steps

Tool Delivery

1. The activity light on the **rover** turns yellow for autonomous driving.
2. The **rover** is outfitted with a repeater and is required to carry it until the end of this stage.
3. The mission starts in the airlock of the **Moon Base** and the **rover** moves out of the airlock.



4. The **rover** navigates to the drop area given by the coordinates.
5. The **rover** comes to a full stop and drops the repeater in the drop area.

Lava Tube Exploration

6. The **rover** navigates to the lava tube entrance given by the coordinates and passes through the entrance.
7. The **rover** measures the distance from the entrance of the lava tube to the colored cardboard.
8. The **rover** exits the lava tube and reports back with measurement results.

Return to the Base

9. The **rover** navigates to the airlock, avoiding any obstacles along the way.
10. The **rover** enters the airlock.

7.1.2.2 Mission Details

Teams are prohibited from communicating with their **rovers**, including the issuance of start and stop commands. Prior to the beginning of the mission, the ARC crew will provide a communication module to the competing **rover**. This module is exclusively for the ARC crew's use to relay instructions to the **rovers**. Consequently, all mission directives will be transmitted via this module. The **rovers** will operate without their own antennas, requiring teams to detach any antennas from the **rovers** at the mission's onset. During the preparation time, the ARC judge crew will evaluate the **rovers** and may request teams to remove any system that resembles an antenna. In the preparation phase, teams are allowed to link their **rovers** to the Rover Satellite Communications Client Module (RSC-CM) using the RS-232 connection, as detailed in section **7.1.2.2.1. The RSC-CM** operates using a unique message format named the **Rover Satellite Communications Protocol (RSCP)**.

7.1.2.2.1 Rover Satellite Communications - Client Module (RSC-CM)

The **RSC-CM** will be equipped with a 9-hole DB9 female socket and will use RS-232 communication protocol. It will operate at a baud rate of 115200 bps, have 1 stop bit, and will not use parity or additional stop bits. The **RSC-CM** module will employ the RSCP framing protocol for data transmission to and from the **rovers**. This protocol includes various message types, like "ArmDisarm," "NavigateToGPS," and others. The **RSC-CM** module will operate independently without needing an external power source, as it will have its own internal power supply. It will weigh less than 1kg and will be roughly the size of a credit card. For detailed information, please refer to the external documentation available in the GitHub repository.

7.1.2.2.2 Message Format: Rover Satellite Communications Protocol (RSCP)

RSCP is a specialized protocol designed for communication with **rovers** over a serial connection during the ARC mission. The RSCP protocol is crucial for coordinating and instructing the **rover's** actions throughout the mission. The RSCP protocol serves as the primary means of communication between the mission control center and the participating **rover** teams during the





ARC challenge. It facilitates the transmission of mission directives, status updates, and control commands to the **rovers**, ensuring smooth mission execution.

The detailed technical aspects, including the frame structure and Python/C++ code examples, will be available in the external documentation for reference. Teams are advised to refer to this documentation for a deeper understanding of the RSCP protocol's inner workings. Teams can access the documentation with the link on the ARC website along with the ARC Manual. This link will be forwarded to a GitHub repository. Teams must follow the updates in this repository until the date specified in section **2.3.1. Milestones**, as this documentation will also include crucial message timings, example communication flows and sequences, which will be mandatory for the execution of this mission.

Tool Delivery Details:

1. **Rover** should be able to show its operational status with a light. The light should have red, green, and yellow colors. See **3.1.5.1. Activity Light** section for details.
2. The **rover** is equipped with a **repeater** at the **moon base** while it is being prepared for the mission. The **rover** starts the mission with this repeater onboard. The sketch of the repeater can be found in the **Technical Details** section of the manual. Teams will not face any restrictions on how to transport the repeater. They can opt to use their robotic arm or a simple hatch mechanism or any system eligible for carrying it. Feel free to use your imagination!
3. Before starting the mission, since the manual control of the **rover** violates the rules, the judge validates the autonomy of the **rover**. The judge has the authority to perform the necessary checks in case of suspicion that the **rover** is being controlled manually. After the validation, the rover is placed in the **moon base's airlock** by the team members. If the size of the **rover** does not comply with the limitations, the team skips this step and starts the mission at the endpoint of the airlock.
4. The **rover** is required to navigate to the area, centered on the exact GPS coordinates provided in the navigation message coordinated by **RSC-CM**. To be considered entered, the **rover** must come to a complete stop and report back the task finished message, regardless of its stopping position within the range. Additionally, the initial position of the **rover** (Airlock Coordinates) will be given. Teams that choose not to use GPS sensors in their system can, by knowing the base position, opt to compute the local coordinates of the specified target GPS point. They can then navigate to this point using exclusively local navigation algorithms.
5. After coming to a stop and transmitting the task finished message, the **rover** must release the equipped payload onto the ground. The points awarded will be based on the distance between the drop point and the provided GPS point. Repeaters positioned beyond the specified limits will not be considered a successful drop. Refer to Section **4.14 "Criteria for Reaching Target"** for details. The communication server will not instruct the **rover** to drop the payload; therefore, after transmitting the task finished message, the **rovers** are expected to release the payload on their own. Once the distance between the dropped payload and the GPS point has been measured, the **rover** will receive the next task from





the communication server. The communication server will not include the time taken by judges to measure the distance in its calculations. Any movement before the communication server assigns the next stage tasks will result in a penalty. Additionally, relocating the dropped repeater through any form of contact, such as hitting or crashing, will also result in a penalty, whether it was accidental motion or running over the repeater.

Lava Tube Exploration Details:

6. **Rovers** are required to navigate to the lava tube entrance, either by using custom detection algorithms or by detecting the two Aruco markers placed at the entrance of the lava tube. Teams are advised not to depend on GPS inside the lava tube due to the lack of a guaranteed signal. The width of the lava tube will be within the range of 2.25-2.5 meters and remain consistent throughout. Additionally, the relevant markers are included in the **Technical Details** section; including their size, identification number, and position of placement on the entrance.

7. The rover must utilize its onboard sensors to measure the distance to a colored cardboard placed inside the tunnel, which covers the entire ground. The distance information represents a 1D position, indicating the distance from the entrance of the lava tube to the cardboard, following the expected spline path rather than the rover's actual trajectory. Teams are encouraged to track their rover's movement to accurately localize within the lava tube and ensure the distance information is precise. The scoring for distance measurement will be based on the calculated error. Teams will not get any scores, if the distance measurement has an absolute error larger than 2m. The rovers are then required to transmit the detected cardboard's distance back to the communication server. Rovers that successfully deploy the repeater in the correct area in the previous stage (**Tool Delivery**) can report the distance information while inside the tunnel. However, rovers that fail to position the repeater in the designated area will not receive points, if they report the cardboard's distance while inside the lava tube. For this, the rover must properly exit the lava tube, then report back to the communication server.

8. The **rovers** are required to exit the lava tube without any contact with the inner walls in order to be able to get full points. Teams are accountable for ensuring their **rover** exits the lava tube entirely before reporting the sensor measurements as communication inside the lava tube is not guaranteed, if the **Tool Delivery** stage was not successful. Also, teams that choose to skip stage 1 (**Tool Delivery**) or attempt stage 2 (**Lava Tube Exploration**) before stage 1(**Tool Delivery**), will not be able to report the position of the cardboard while inside the tunnel.

Return To The Base Details:



9. There is no assurance of a path without obstacles. The route the **rover** follows to return to the airlock is entirely the team's decision, except for re-entering the lava tube. The **rover** should pass around the obstacle to reach the airlock of the Moon Base.
10. Two Aruco markers will be positioned on opposite sides of the airlock gate, facing the direction from which the **rover** is anticipated to enter. The entrance of the airlock will be clear of obstacles. Refer to section **8.6 Marker** for marker details.

7.1.3. Mission 3: Lunar Robotic Prospector

Time Limit: 30 Minutes

Mission Field: Moon

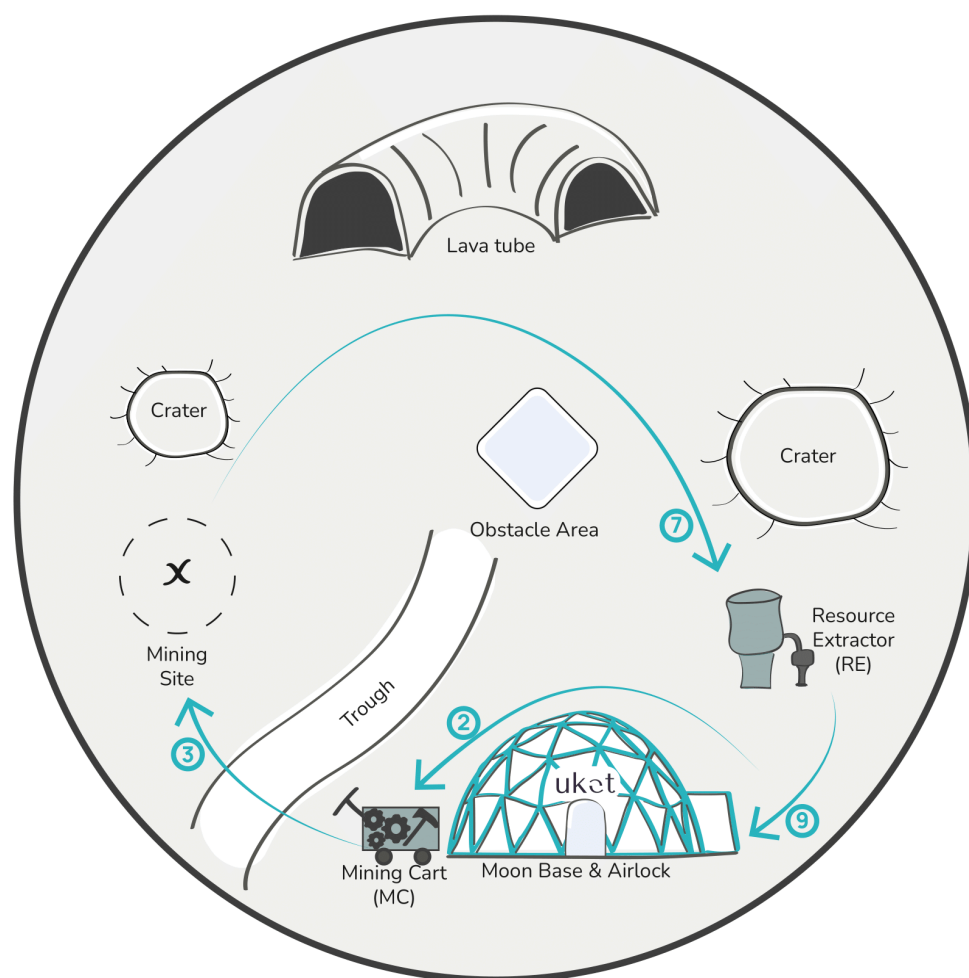

7.1.3.1. Mission Steps

1. The mission starts in the **airlock** of the **Moon Base**.
2. The **rover** goes to the **Mining Cart (MC)**.
3. The **rover** transports the **MC** to the designated mining area.
4. Upon arrival at the mining site, the **rover** manipulates the mechanisms on the **MC** to start the mining process.



- a. **Rover** pulls 3 solar panel release pins.
 - b. **Rover** adjusts the slider to select mining mode.
 - c. **Rover** pulls the lever to start the power for mining.
5. The **rover** waits for the mining process until the container is full. While waiting the **rover** can turn the handwheel for a certain amount to accelerate the mining process.
 6. The **rover** opens a lid to take the container out.
 7. The **rover** carries the container to the **Resource Extractor (RE)** near the base.
 8. The **rover** puts the container inside of the **RE** properly.
 9. The **rover** then returns to the **airlock**.

7.1.3.2. Mission Details

1. The **rover** starts the mission in the **airlock** of the **Moon Base**. From there, the **rover** should visit the **mining cart** location and **mining site**.
2. The **rover** navigates to the **mining cart** which is placed next to the **Moon Base**.
3. The **rover** carries the **mining cart** to a designated **mining site**; the location of the designated area will be given to the teams. There are two paths; the short path and the long path. The short path is rough but the long path is a straight road. To get all the necessary information regarding the size and weight of the **cart**, check the related page in the **Technical Details** section for the cart.
4. At the **mining site**, teams will be awarded points according to how accurately they place the **mining cart**. The **rover** must deploy the **mining cart** by:
 - Pulling out 3 securing pins, allowing the instrument to stand on its feet and unfold its solar panels.
 - Adjusting the slider for mining mode selection
 - Pulling the lever in order to turn the power on

These steps simulate setting up an autonomous **Resource Extractor** on the Moon. The **mining site** will be indicated with a flag at the center. The **rover** is required to be near the flag within 2 meters. The radius will be checked by the judges. To get points from this step the **rover** has to be in the area. To see blueprints of the **pins**, **slider**, and **lever** and get all the necessary information, check the related page in the **Technical Details** section for the pins, slider, and lever.

5. As the mining progresses, the rover actively monitors the process. It can turn a handwheel on the **MC** to adjust the mining speed, which will accelerate the filling of the container. If the handwheel is not rotated, the container gets filled automatically at a rate that gets fully filled in 20 minutes. Each complete rotation increases the filling rate by half of the default filling rate. There is no limit for the rotations of the handwheel and filling speed of the container. When the lid on the **MC** is opened, the filling of the container is stopped. To see blueprints of the **handwheel** and **lid** and get all the necessary information, check the related page in the **Technical Details** section for the handwheel and lid.
6. The rover opens a lid on the **MC** to carefully remove the container. The teams can open the lid and start carrying the container whenever they wish, considering the



MC is turned on (**MC** lever is actuated). The teams will get rewarded depending on the fullness of the container. To see the blueprints of the **container** and get all the necessary information, check the related page in the **Technical Details** section for the container.

7. With the filled container, the rover moves to the **Resource Extractor (RE)**, situated near the base. To see the blueprints and location of the **RE** and get all the necessary information, check the related page in the **Technical Details** section for the **RE**.
8. Upon arrival at the **RE**, the rover places the container inside the station with precision.
9. The **rover** completes the mission by entering the **airlock**.

7.1.4. Mission 4: Night Launch

Time Limit: 15 Minutes

Mission Field: Mars

Mission Time: After sunset

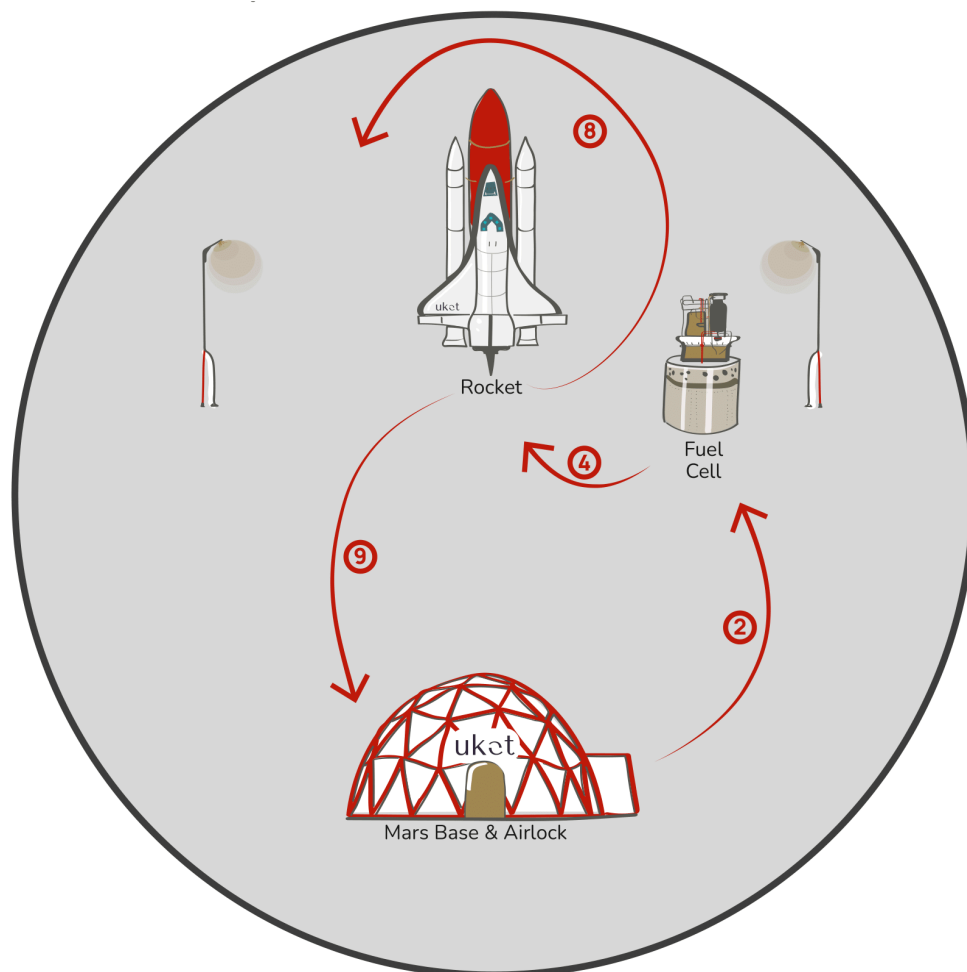



7.1.4.1. Mission Steps

1. The mission begins with the **rover** leaving the airlock.
2. The **rover** moves towards the fuel cell.
3. The **rover** switches the fuel cell on.
4. The **rover** takes the first photo of the rocket from the perspective of light source 1.
5. The **rover** takes a second photo of the rocket from the perspective of light source 2.
6. The **rover** moves towards the rocket.
7. The **rover** should take a photo of the Launch Readiness Inspection screen showing the launch time.
8. The **rover** circles around the rocket and takes a close-up photo of the rocket's landing legs.
9. **Rover** returns to the airlock.

7.1.4.2. Mission Details

1. The **rover** begins the mission by leaving the **airlock** of the **Mars Base**.
2. The **rover** should find the fuel cell and move towards it. For the dimensional details of the Fuel Cell, please check the related page in the **Technical Details** section.
3. After reaching the fuel cell, the switch should be turned on to power the light sources and the rocket's computer. The switch will be a lever-type electrical connector.
4. The **rover** should take two different photos of the rocket from the positions of the light sources. Therefore, the **rover** should reach the light sources and take a photo of the rocket.
5. It might be required to take multiple shots to cover the whole rocket.
6. The **rover** moves to the rocket launch pad area.
7. **The Launch Readiness Inspection screen** on the rocket, which has a backlit illuminated thanks to the Fuel Cells, can now be seen. The **rover** should take a photo of the Launch Readiness Inspection screen on the rocket.
8. The **rover** should circulate around the rocket to find the connectors and take a photograph with the help of external lights.
9. The **rover** should navigate back and enter the **airlock** so that no part of it is left outside of the **airlock**.

7.2. Side Missions

7.2.1. Challenge to Shine

Time limit: 10 minutes with each **judge**

This side challenge is a presentation challenge of the ideal rover design of the team to experts in their fields. The presentations made in this challenge are evaluated separately and not





be included in the general challenge score. The fields of the experts are science, autonomous driving and control, robotic arm, driving in difficult terrain, and team structure, etc. Team members will have 10 minutes to present their approach to the stated fields during this challenging process to the **judges** in different rooms. The presentations will be evaluated, and the **judges** will choose the winner of each field. Prizes will be given to the winning teams. Each field can only have one winner.

7.2.2. Side-Challenges

During challenge days, there will be side-challenges that are not a part of the main challenge. These challenges are a set of games and mostly require **rover-teammate and multi-rover** interaction. All of the winners will get special awards. The ARC Committee has all rights to make changes to side-challenges until the competition day. They are planned to be held on the last day of the competition.

7.2.2.1. Rover's Mystery Canvas

Step into **Rover's** Mystery Canvas, where every stroke holds a surprise waiting to be discovered. **Rovers** will use the given paints to uncover the unknown and create memorable memories.

7.2.2.2. Victoria's Rover

Teams decorate their **rovers** with clothes and accessories of their design, using the materials we provide. **Rover** takes a tour of the runway. Traditional clothing is encouraged.

7.2.2.3. Disco Rover

Teams will play their chosen song and dance their **Rovers** to specific **Rover** dance figures. The **team** that executes the figures the best wins the **Rover** game.

7.2.2.4. Rover Treasure Hunt

Teams attempt to locate small clue notes we've placed on the field beforehand. The notes contain riddles about the **Rovers** they need to solve. Each **team** that finds and solves a clue is rewarded with a prize related to that clue.

7.2.2.5. Rover Jenga

Rovers and optionally, **team-mates** will play with **Rover**-sized Jenga pieces. It can also be played by the participants, optionally. They should be careful and precise so as not to drop the blocks.

7.2.2.6. Egg and Rover Challenge

The **rovers** will carry a special space egg on a special spoon without cracking the egg. The important thing is the balance of the **rover**; the drivetrain and robotic arm capabilities will be



challenged.

7.2.2.7. Nascarover

A track with curves and different terrain conditions is prepared and the rovers race on this track (Our competition area can be turned into a track.). **Rovers** should have good terrain control.

8. Technical Details

8.1 Sample Tube & Rocket

8.1.1 Sample Tube Sketch

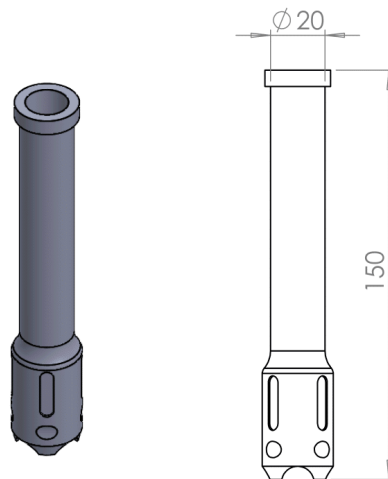

8.1.2 Rocket Sketch

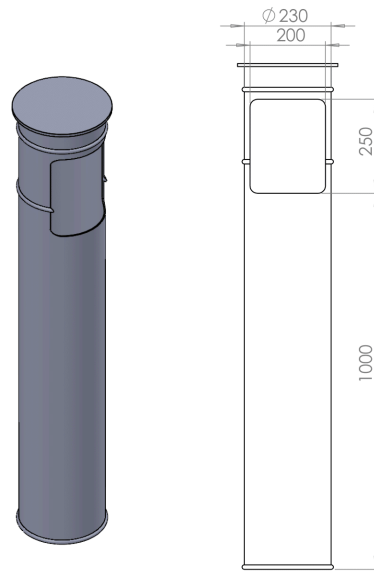

8.2 Repeater

8.2.1 Repeater Sketch

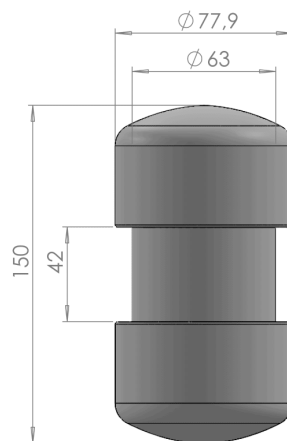

8.3 Mining Cart (MC)

8.3.1 MC Sketch

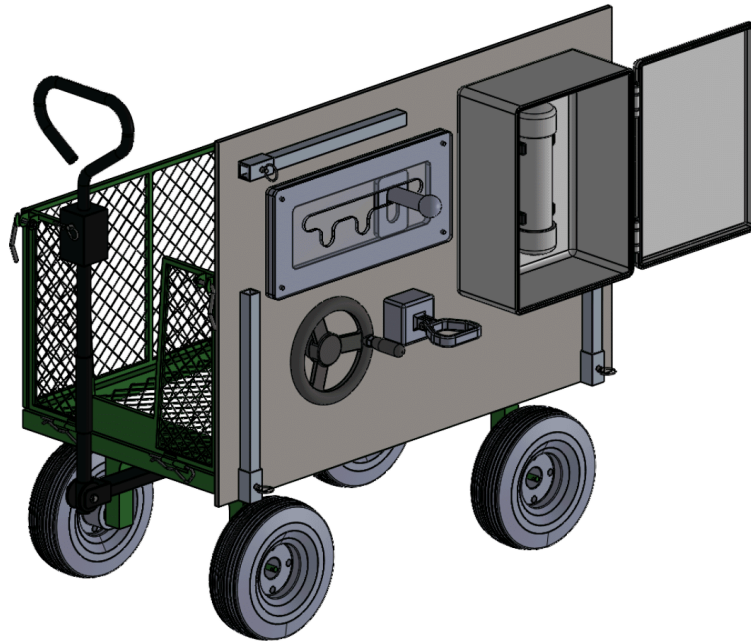

Dimensions (Length x Width x Height): ~ 1100 x 505 x 495 mm

Dimensions with Carrying Handle (Length x Width x Height): ~ 1100 x 505 x 940 mm

Weight: ~20 kg

8.3.1.1 Mining Cart

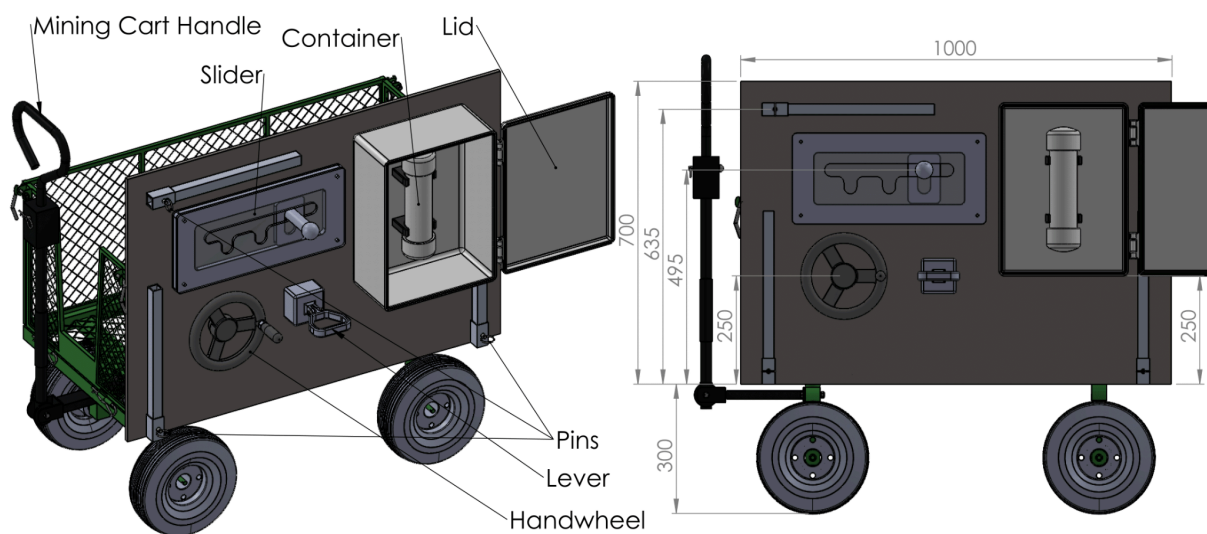

8.3.1.2 Pins

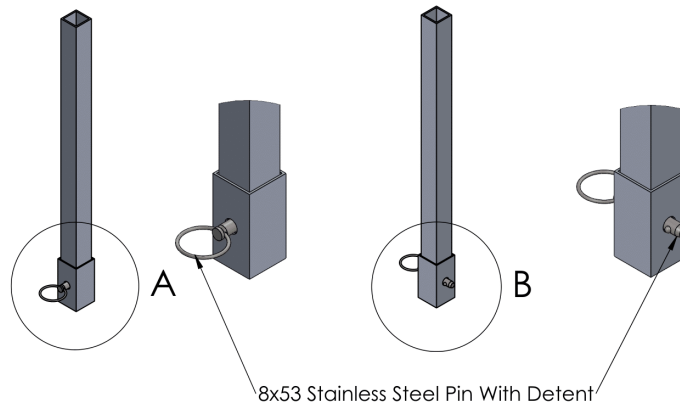

8.3.1.3 Slider

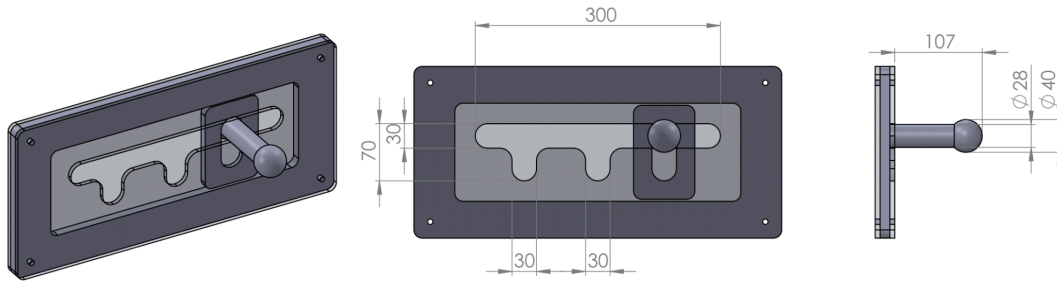

8.3.1.4 Lever

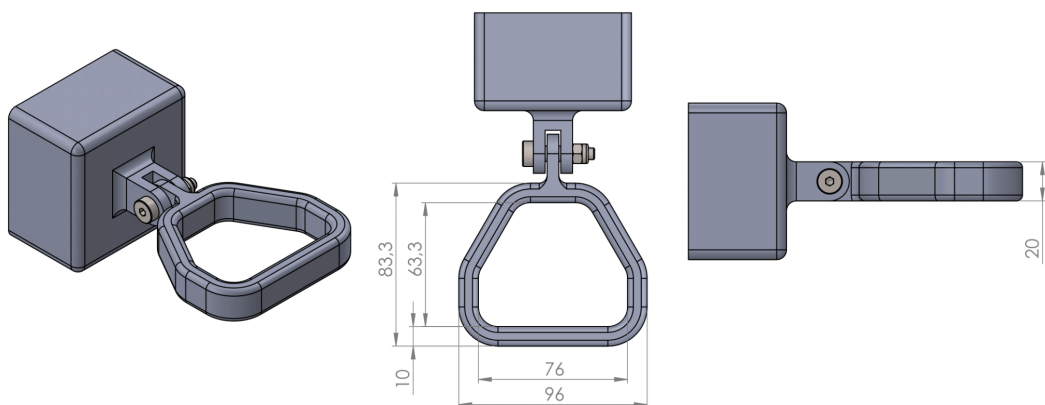

8.3.1.5 Handwheel

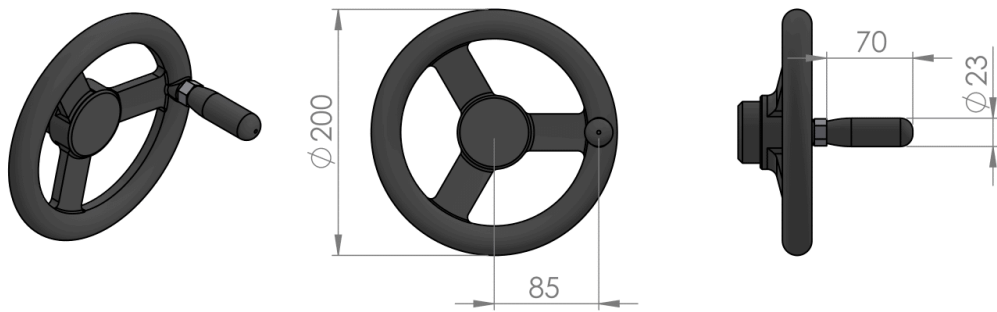

8.3.1.6 Container & Lid

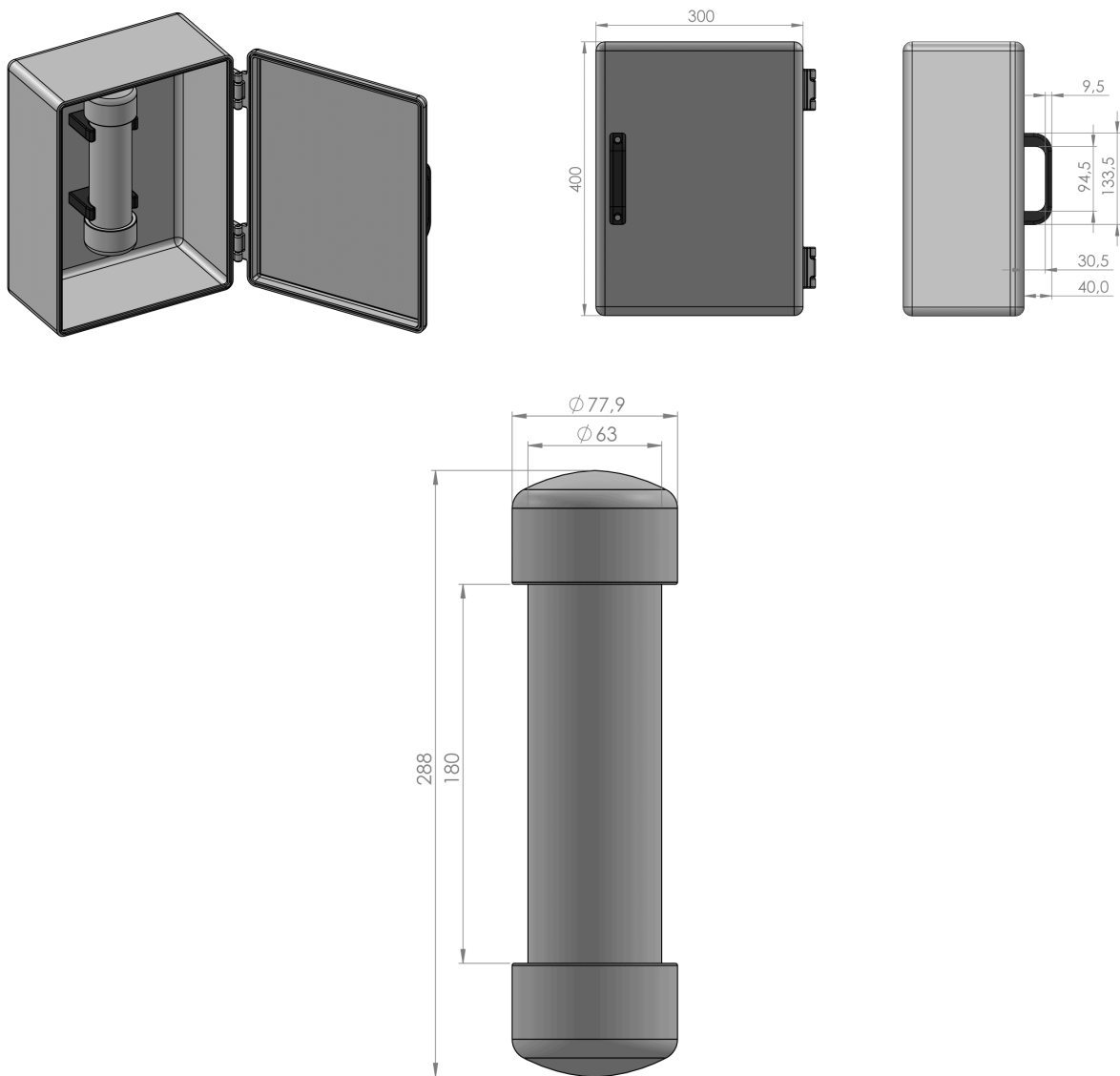

8.3.2 MC Steps:

1. **Rover** pulls the pins.
2. **Rover** adjusts the slider.
3. **Rover** pulls the lever.
4. **Rover** turns the wheel.
5. **Rover** opens the lid.
6. **Rover** takes the container.

8.3.3 MC Details:

1. The **Rover** pulls the three pins.
2. The **Rover** adjusts the slider, making sure to select the correct mining mode.
3. The **Rover** pulls the lever.
4. The **Rover** turns the handwheel.
5. The **Rover** opens the lid.
6. The **Rover** takes the container from the cart.

8.4 Resource Extractor (RE)

8.4.1 RE Sketch

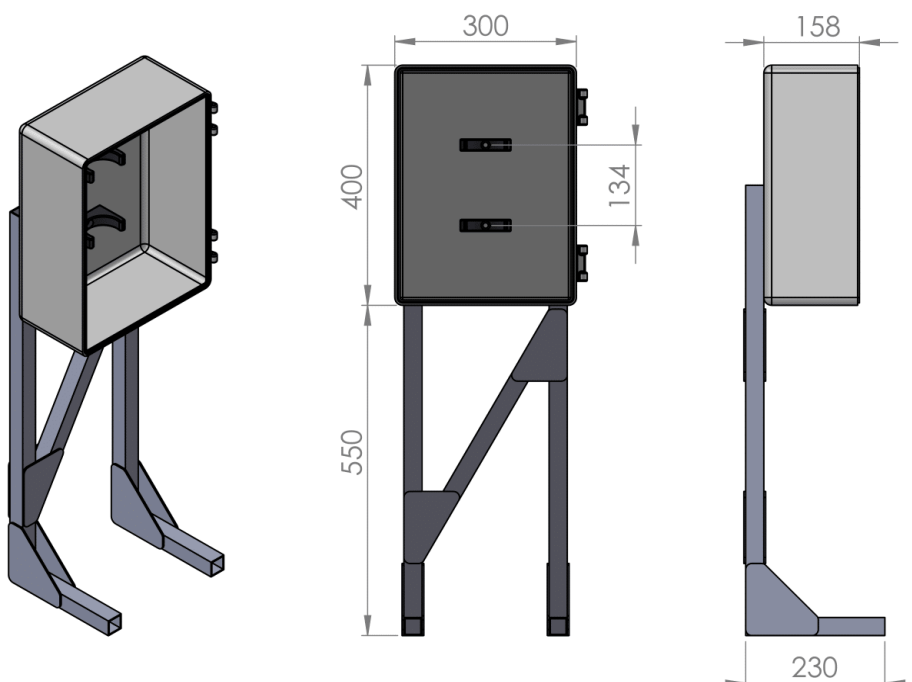

8.4.2 RE Steps:

1. **Rover** puts the container inside of the **RE**.

8.4.3 RE Details:

1. **Rover** attaches the container to the **RE** so that it is fully supported by the container holding clip.

8.5 Fuel Cell

8.5.1 Fuel Cell Sketch

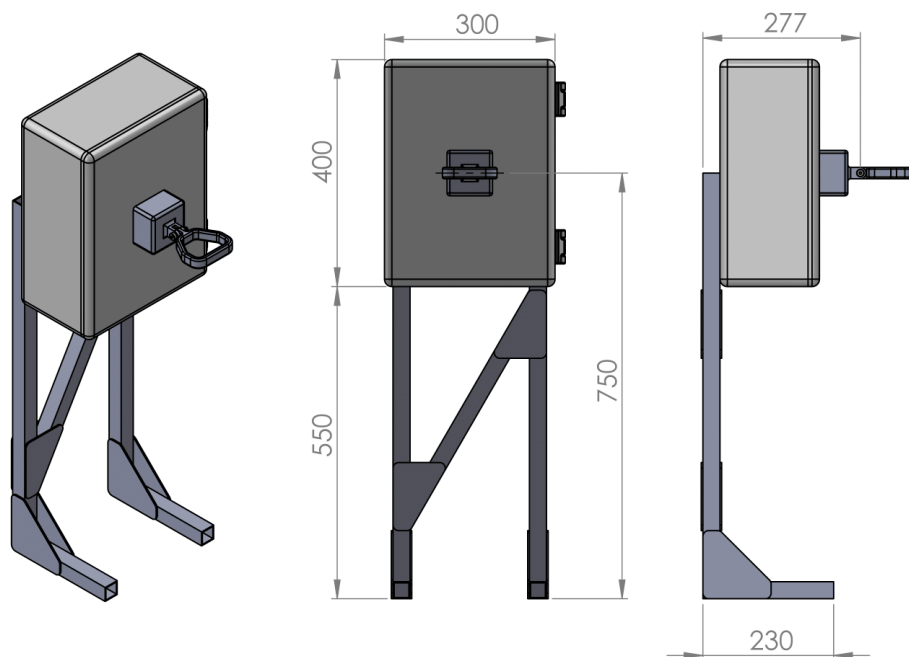

8.5.2 Fuel Cell Steps:

1. **Rover** switches the fuel cell on.

8.5.3 Fuel Cell Details:

1. A lever-type electrical connector switch turns on, and turning on the switch activates the lights.

8.6 Marker

All the markers are of the size 20x20 cm.

1.M1

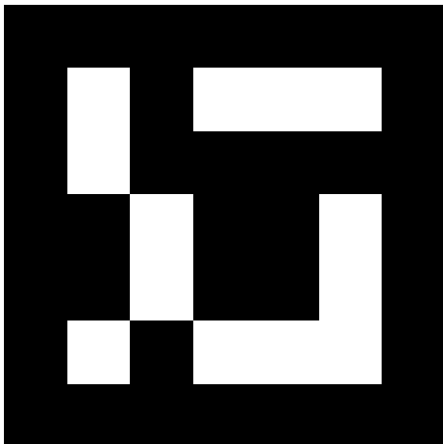

(The marker placed on the right and left hand side of the Airlock)

(The marker placed on the entrance of

3. M3

2. M2

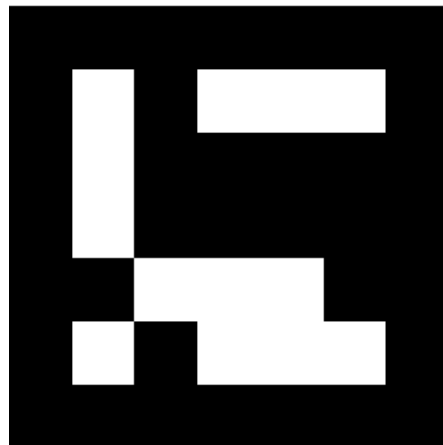

the lava tube)

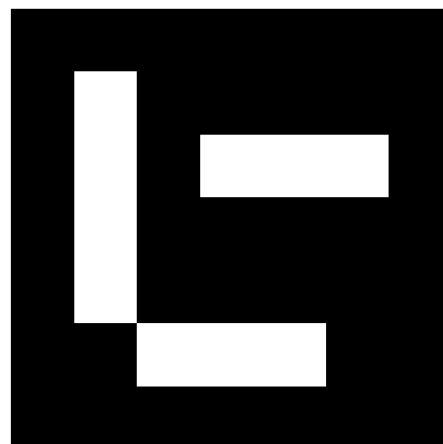



(The marker placed on the exit of the lava tube)

9. Score Tables

9.1. Final Qualification

Finals Qualification scores are calculated according to the following formula: "0.50 x Design Report Score + 0.50 x Video Presentation Score"

9.1.1. Design Report

Design Report scores will not affect mission scores but affect the elimination process to select the finalist teams. The scoring will be conducted by the following table.

No	Title	Description	Detail	Score
1	Team Info	Team Name	Name of the team and if applied, name of the rover.	1
2		Contact	Contact information and social media links of the team	1
3		Academic Institution	Name and address of the affiliated academic institution.	1
4		Academic Consultant	Name, affiliated academic institution, and contact information of academic consultant.	1
5		History of the team	A paragraph of team history including foundation date, attended competitions, and experience.	5
6		Active Members List	A table of active members including the following information: Name (or initial letters), University Major, and duty in the team.	2
7		Team Photo	A photo/screenshot of the whole or part of the team.	1
8	Management	Work Calendar	Explain the work on the project by a Gantt chart. Include 10-15 items in the Gantt chart.	10
9		Team Formation	How is the team workforce structured? (2-3 sentences) Include a graphic to explain the structure as well.	5
10		Workplace	How does the team design, build, and test the rover physically? Explain the workplace. (2-4 sentence) Include a photo/screenshot of the workplace.	3





No	Title	Description	Detail	Score
11		Funding	How are the funds of the project at the time of submission of this document?	2
12			How much spending is expected for the development costs? How much spending is expected for the travel costs?	2
13			What is the team's plan in an insufficient funding situation by the competition date?	2
14		Logistics	What is the team's plan to package and bring the rover to the competition site by July? (4-6 sentences)	4
15	Rover Design	Mobility system	What is used? Describe the system (3-5 sentences)	12
16			Why is the system chosen? What are the considerations? What are the weaknesses and strengths? (3-5 sentence)	
17			Unique points and inspirations (3-5 sentences)	
18			Visuals of the system (2 photos/screenshots)	
19			Technical Specifications including mass and size (3-5 sentences)	
20			Discuss the system's adequacy for its role in competition missions. (3-5 sentences)	
21		Electronics and power system	What is used? Describe the system (3-5 sentences)	12
22			Why is the system chosen? What are the considerations? What are the weaknesses and strengths? (3-5 sentence)	
23			Unique points and inspirations (3-5 sentences)	
24			Visuals of the system (2 photos/screenshots)	
25			Technical Specifications including mass and battery duration (3-5 sentences)	
26			Discuss the system's adequacy for its role in competition missions. (3-5 sentences)	
27	Manipulation system	What is used? Describe the system (3-5 sentences)	12	
28		Why is the system chosen? What are the considerations? What are the weaknesses and strengths? (3-5 sentences)		
29		Unique points and inspirations (3-5 sentences)		
30		Visuals of the system (2 photos/screenshots)		
31		Technical Specifications including mass, max payload, and size (3-5 sentences)		
32		Discuss the system's adequacy for its role in competition missions. (3-5 sentences)		
33			What is used? Describe the system (3-5 sentences)	12





No	Title	Description	Detail	Score	
34		Science Payload	Why is the system chosen? What are the considerations? What are the weaknesses and strengths? (3-5 sentence)		
35			Unique points and inspirations (3-5 sentences)		
36			Visuals of the system (2 photos/screenshots)		
37			Technical Specifications including mass and sensors (3-5 sentences)		
38			Discuss the system's adequacy for its role in competition missions. (3-5 sentence)		
39		Ground station equipment and communication system	What is used? Describe the system. (3-5 sentence)		12
40			Why is the system chosen? What are the considerations? What are the weaknesses and strengths? (3-5 sentence)		
41			Unique points and inspirations (3-5 sentences)		
42			Visuals of the system (2 photos/screenshots)		
43			Technical Specifications including resilience to noise and communication range (3-5 sentences)		
44	Discuss the system's adequacy for its role in competition missions. (3-5 sentence)				
TOTAL				100	

9.1.2. Video Presentation

Video Presentation scores will not affect mission scores but affect the elimination process to select the finalist teams. The scoring will be conducted by the following table.

No	Title	Description	Detail	Score
1	Team Info	Team Name	Name of the team and if applied, name of the rover.	8
2		Academic Institution	Name of the affiliated academic institution.	
3		History of the team	The team's history including foundation date, attended competitions, and experience.	
4		Team Visual	A photo/screenshot/video of the whole or part of the team.	
5	Management	Workplace	How does the team design, build and test the rover physically? Explain the workplace.	2
6	Rover	Mobility	What is used? Describe the system.	6





7	Design	system	Technical Specifications including mass and size.	8	
8			Why is the system chosen? What are the considerations?		
9			Visuals of the system to show mechanisms.		
10			Demonstration of the system with ARC'24 mission objectives in mind.		
11		Electronics and power system	What is used? Describe the system.	Technical Specifications including mass and size.	6
12				Why is the system chosen? What are the considerations?	
13				Visuals of the system to show mechanisms.	
14				Demonstration of the system with ARC'24 mission objectives in mind.	
15				Demonstration of the system with ARC'24 mission objectives in mind.	
16		Manipulation system	What is used? Describe the system.	Technical Specifications including mass and size.	6
17				Why is the system chosen? What are the considerations?	
18				Visuals of the system to show mechanisms.	
19				Demonstration of the system with ARC'24 mission objectives in mind.	
20				Demonstration of the system with ARC'24 mission objectives in mind.	
21		Science Payload	What is used? Describe the system.	Technical Specifications including mass and size.	6
22				Why is the system chosen? What are the considerations?	
23				Visuals of the system to show mechanisms.	
24				Demonstration of the system with ARC'24 mission objectives in mind.	
25				Demonstration of the system with ARC'24 mission objectives in mind.	
26		Ground station equipment and communication system	What is used? Describe the system.	Technical Specifications including mass and size.	6
27				Why is the system chosen? What are the considerations?	
28				Visuals of the system to show mechanisms.	
29				Demonstration of the system with ARC'24 mission objectives in mind.	
30				Demonstration of the system with ARC'24 mission objectives in mind.	
31		Whole Rover	Demonstration of the system with ARC'24 mission objectives in mind.	10	
32		Video Clarity		Quality of the content and presentation	10
TOTAL				100	

9.1.3 World Rover League





The World Rover League (WRL) is a global space robotics league for university students, including all competitions and teams in the world to date organized by SPROS and UKET, in which teams conceptualize, design, develop, and operate an astronaut-assistive next-generation planetary rover in simulated conditions.

9.2 Finals Scoring

Challenge scores are stated in the tables below. Each mission has 100 and all missions have 400 points. Teams are evaluated with the sum of all mission scores at the end of the challenge. The top three teams that get the maximum overall points will be selected as winners and awarded respectively.

9.2.1. Mission 1: Science Sampler (Mars Field)

No	Section	Parameter	Step Score	Detailed Explanation
1	Landing	Taking photograph of sampling site	5	At least 3 photographs must be taken
2	Landing	Taking panoramic photograph	3	All geomorphological structures should be covered with the images.
3	Landing	Measurements with basic sensors	3	T, p, pH, NPK
4	Landing	Experiments and measurements with onboard equipments	12	Rover instruments developed by the rover team to obtain onboard experiments or measurements must be used to gather the point. (Each instrument will be 4 points, up to 3 individual instruments may provide maximum of 12 points in this step)
5	Landing	The depth of sample site (min 5 cm)	2	The point is applicable only if min 5 cm rule applied
6	Bonus- Extra Sample Collection	The depth of sample site (min 5 cm)	1	The point is applicable only if min 5 cm rule applied (If there is no closed and sealed container no score granted)
7	Landing	Gathering sample with closed and sealed container	3	If there is no closed and sealed container no score granted
8	Bonus- Extra Sample Collection	Gathering sample with closed and sealed container	2	If there is no closed and sealed container no score granted
9	Landing	Reaching Mars base after sampling	2	Full airlock entrance is required if any part of the rover remains outside of airlock no score will granted and base crew cannot manipulate rover for rest





				of mission
10	Exploration	Delivering sealed container to judge inside Mars base	2	
11	Exploration	Weighting main sample	3	Sample must be delivered to the base by the rover, and weighted at least 5 g by the judges at the base
12	Bonus- Extra Sample Collection	Weighting main sample	2	Sample must be delivered to the base by the rover, and weighted at least 5 g by the judges at the base (If there is no closed and sealed container no score granted)
13	Exploration	Navigating to the previously dropped sample site	2	
14	Exploration	Picking sample from ground	2	
15	Bonus Score- previously dropped sample	If an extra container available onboarded to rover for carrying sample	3	If the team designs a container system to carry the previously dropped sample, it will be rewarded.
16	Exploration	Reaching to the rocket	2	
17	Exploration	Inserting sample to the rocket	2	
18	Exploration	Navigating back to Mars base	2	
19	Exploration	Entering to the airlock	2	The rover has to arrive at the location of the Mars Base
20	Presentation	Explaining selection of sampling area	4	It must be explained in the context of the scientific hypothesis.
21	Presentation	Showing photographs during mission	2	The photograph must be gathered during this mission.
22	Presentation	Explaining mission area	2	
23	Presentation	Showing photographs of site sampling area	2	The photograph must be scaled, and it must be gathered during this mission.
24	Presentation	Explaining photographs of the sampling area	3	
25	Presentation	Showing panoramic photographs	2	The photograph must be gathered during this mission.
26	Presentation	Explaining panoramic photographs	3	Geomorphological structures in the region must be identified.





27	Presentation	Explaining stratigraphy of mission area	5	Geomorphological structures in the region must be evaluated in terms of time relations. The geological history of the region must be explained using photographs of the cross-cutting structures. To define the relative age of the unit, in which the sample was taken, it should be compared with the other units in the area.
28	Presentation	Identifying sample	3	The sample provided by the judges should be identified
29	Presentation	Explaining sample	2	The sample provided by the judges should be described
30	Presentation	Explaining experiments	3	For onboard experiments
31	Presentation	Explaining experiments	3	For laboratory experiment
32	Presentation	Identifying suitability of experiments for sample	3	The result of the experiment must be explained in the context of the scientific hypothesis. Rejecting or confirming the hypothesis must be explained with their reasons.
33	Presentation	Identifying suitability of area and sample relationship	2	Is it meaningful to find this sample in that location?
34	Presentation	Showing onboarded sensor results in table with screenshots	2	Data must be gathered during this mission. If not, the onboard score will be half.
35	Presentation	Explaining sensor results with frame of experimental results	2	
36	Bonus Score-Presentation	Explanation of -mystery- with frame of scientific inference	2	In order to obtain the bonus point, geological knowledge on Mars will be important.

9.2.2. Mission 2: Autonomous Exploration (Moon Field)

No	Parameter	Step Score	Detailed Explanation
1	Entering the circle	15	The rover must go to the given location for tool delivery.
2	Dropping the repeater	5	The rover must drop the repeater.
3	Going to lava tube entrance	5	The rover must go to the given location of the lava tube entrance.





4	Entering the lava tube	10	The rover should enter the lava tube without touching the borders of it.
5	Measuring the distance in lava tube	20	Measuring the distance from the entrance of the lava tube to the colored cardboard.
6	Exiting the lava tube	25	The rover should exit the lava tube without interfering with the boundaries of the lava tube.
7	Getting in front of the airlock.	10	For the rover to enter the airlock, it must go in front of the airlock, avoiding obstacles.
8	Getting in through the airlock	10	The rover must enter the airlock with the help of the markers on the Moon Base.

No	Penalties	Amount	Detailed Explanation
1	Detection of the rover being remotely controlled during the mission	-100%	No scores can be taken from the mission.
2	Damage to objects on the field	-10%	Resulting in a 10% deduction from the team's total Mission 2 scores for each object damaged.
3	Touching the systems	-5%	Result in a 5% deduction from the team's total Mission 2 scores for each touching
4	Any part of the rover going out of the field	-5%	Scores are broken and continue from the last successful step of the mission.
5	Shutting down the rover with communication	-5%	Because an emergency has occurred that the red button could not be reached.
6	Repetition of the mission step	-20% (step score)	For each repetition of the step, 20% of the step score is deducted. e.g. repeating the second step (10 points) 2 times deducts 3 points from the mission score.

9.2.3. Mission 3: Lunar Robotic Prospector (Moon Field)

No	Parameter	Step Score	Detailed Explanation
1	Reaching the mining cart	5	The rover must be near the mining cart.





2	Towing mining cart to the mining site	15	The mining cart must be completely within the site.
3	Releasing all the pins	15	Teams get awarded for each released pin independently.
4	Adjusting the slider	12	The rover must adjust the cart's slider to get the full points
5	Pulling the lever	8	The rover must pull the cart's lever to get the full points
6	Points are awarded according to the container fill amount.	12	The container stops filling as soon as the lid is opened
7	Opening the lid	6	The rover must open the cart's container lid
8	Carrying the container	12	The rover must carry the container to the RE
9	Putting the container	10	The rover must put the container into the RE
10	Entering to the airlock	5	The rover should enter the airlock so that no part of it is left outside of the airlock

No	Penalties	Mission Score	Detailed Explanation
1	Causing any kind of damage to the panels	-10%	Results in a 10% deduction from the total Mission 3 scores for any damages to the panels

9.2.4. Mission 4: Night Launch (Mars Field)

No	Parameter	Step Score	Detailed Explanation
1	Navigating to the Fuel Cell	10	The rover should find the fuel cell and reach it from the airlock.
2	Switching the Fuel Cell lever on	20	In order to activate the fuel cell, the rover should switch the lever to on position. Then, the light source and the rocket's





			power supply will turn on.
3	Taking photos of the rocket near light sources	20	Coverage of the whole rocket from two perspectives required.
4	Navigating to the Rocket	5	The rocket should be seen more clearly by turning on the light sources. The rover should move from the fuel cell to the rocket.
5	Taking a photo of the screen	10	The rover should find the Launch Readiness Inspection screen and take a readable picture.
6	Taking a picture of the connectors	20	The rover should take a picture of the rocket's onboard connectors.
7	Navigating back to the airlock	10	The rover should navigate back to the known location of the airlock.
8	Entering the airlock	5	The rover should enter the airlock so that no part of it is left outside of the airlock.

9.2.5. General Scoring for All Missions

No	Rule
1	Teams can make a maximum of 3 interventions.
2	One intervention deducts 15% of the mission score.
3	Two interventions deduct 40% of the mission score.
4	Three intervention deducts 70% of the mission score.
5	Pressing the emergency button is considered an intervention.
6	Judges can invoke an intervention in case of a security problem or going off-field.
7	In the event of skipping, touching counts as an intervention, thus penalized accordingly.
8	Mission time will continue during Skipping or Intervention.
9	Not turning on the activity light deducts 10% of the mission score.
10	Not having an emergency button on the rover deducts 5% of the mission score.

